

User Manual

MODEL QSDT8PCRC MODEL QSDT8PCDP MODEL QSDT16PCRC

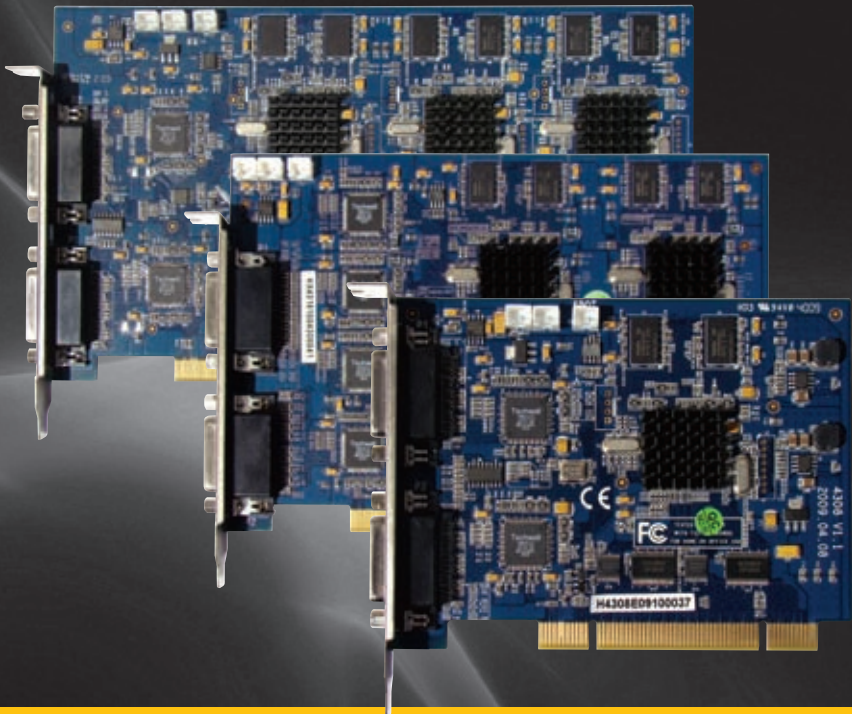

8 and 16 Channel H264 Real Time Recording
PC-Based Network DVR PCI Cards



Thank You for Choosing a Q-See Product!

All of our products are backed by a conditional service warranty covering all hardware for 12 months from the date of purchase. Additionally, our products also come with a free exchange policy that covers all manufacturing defects for one month from the date of purchase. Permanent upgrading service is provided for the software and is available at www.Q-See.com.

Be certain to make the most of your warranty by completing the registration form online. In addition to warranty and technical support benefits, you'll receive notifications of product updates along with free downloadable firmware updates for your DVR. Register today at www.Q-See.com!

Please see the back of this manual for exclusions.



© 2010, 2011 Q-See. Reproduction in whole or in part without written permission is prohibited. All rights reserved. This manual and software and hardware described herein, in whole or in part, may not be reproduced, translated, or reduced to any machine-readable form without prior written approval.

Trademarks: All brand names and products are trademarks or registered trademarks of their respective owners.

Q-See is a registered trademark of DPS, Inc.

Disclaimer: The information in this document is subject to change without notice. The manufacturer makes no representations or warranties, either express or implied, of any kind with respect to completeness of its contents.

Manufacturer shall not be liable for any damages whatsoever from misuse of this product.

About this Manual

This manual is written for the QSĐT8PCRC, QSĐT8PCDP and QSĐT16PCRP security surveillance video capture cards. This manual was accurate at the time it was completed. However, because of our ongoing effort to constantly improve our products, additional features and functions may have been added since that time and on-screen displays may change. We encourage you to visit our website at www.Q-see.com to check for the latest firmware updates and product announcements.

Throughout the manual we have highlighted warnings and other important information that will assist you in operating your new system in a safe and trouble-free manner. Please take the time to read and follow all instructions and pay attention to alerts as shown below:



IMPORTANT! Red boxes with this icon indicate warnings. To prevent possible injury or damage to the product, read all warnings before use.



NOTE! Text in blue boxes with the Information icon offer additional guidance and explanations about how to make the most out of your card.

TABLE OF CONTENTS

1. Introduction	8	6. Recording, Playback and Record Search	26
Features and Specifications	8	6.1 Recording Configuration	26
2. System Requirements and Specifications	10	Basic Configuration	27
2.1 System Requirements	10	Record Status Panel	28
QSDT8PCRP & QSDT8PCDP	10	6.2 Recording Modes	28
QSDT16PCRP	10	Manual Record Mode	28
2.2 System Specifications	11	Sensor Alarm Record Mode	28
3. Video Capture Card Hardware and Connections	12	Motion Detection Record Mode	28
3.1 QSDT8PCDP Card	12	Schedule Recording	29
Video and Audio Pin Layout	13	6.3 Recording to Hard Drive	31
Connecting Multiple Cards	13	6.4 Record Search and Playback	32
3.2 QSDT8PCRP Card	14	Record Search	33
Video and Audio Pin Layout	15	Playback	34
Connecting Multiple Cards	15	6.5 Other Functions	35
3.3 QSDT16PCRP Card	16	File Backup	35
Video and Audio Pin Layout	17	Deleting Recorded Files	36
Connecting Multiple Cards	18	Capture Pictures	36
3.4 Connecting a PTZ Camera	19	Digital Image Zoom	38
4. Installing the SuperDVR Software	20	7. System Settings	39
4.1 Installing the Software	20	7.1 Basic Configuration	40
4.2 User Account Control for Windows Vista and Windows 7	22	Camera Display Settings	40
5. Basic operation	24	Video Configuration	41
5.1 Log In	24	7.2 Alarm Configuration	42
5.2 Display Control Panel	25	Alarm Types	42
Display Modes	25	Triggered Actions	43
Auto Dwell Display	25	7.3 E-map Configuration	45
Page Flip	25	Using the E-Map	46
5.3 Other Controls	25	7.4 User Configuration	47
Snapshot	25	User Rights	47
Urgent Record	25	Add User	48
		8. P.T.Z. Cameras	49
		8.1 P.T.Z Control Configuration	49
		Protocol Setup	49
		Serial Ports Setup	50
		8.2 PTZ Operation	50
		Preset and Group Select	51

9. Remote Surveillance & Playback	52
9.1 Remote Live Surveillance	52
Remote Surveillance Server Configuration	52
9.2 Configuring Router for Remote Access	53
Part 1: Find Out the IP Address of the System	53
Part 2: Determine the Number of Routers on the Network	54
Part 3: Simple Port Forwarding	56
Part 4: Setting Up DMZ in Router 2	61
9.3 DDNS (Dynamic Domain Name Service)	62
Setting up DDNS	62
9.4 Accessing the DVR Using Internet Explorer	63
User Account Control for Windows Vista and Windows 7	63
Accessing the Internet Explorer Client	68
9.5 Remote Playback	71
Record Playback and Control	71
Remote Backup	71
9.6 System Setup	74
Basic Configuration	74
Alarm Setup	75
Camera Setup	76
Schedule Configuration	76
Alarm Configuration	77
Record Configuration	77
Storage Disk	78
Motion Configuration	78
E-mail Configuration	78
9.7 P.T.Z Configuration	80
Protocol Setup	80
Serial Port Setup	80
10. Mobile Surveillance	81
10.1 Windows Mobile Pro	81
10.2 Symbian	83
10.3 iPhone and iPad	85
Installing Through the iPhone or iPad	85
Installing Through PC or Macintosh Computer	87
Operating Instructions for iPhone/iPad	88
10.4 Android	92
Software Installation	92

APPENDIX	97
Frequently Asked Questions	97
Other Questions	100
Quick Start Instructions	102
Installation Instructions	102
Troubleshooting	102
Function Tree	104
System Configuration Tree	105
IE Client Function Tree	106
Remote Playback Function tree	107
Q-SEE PRODUCT WARRANTY	108
Questions or Comments? Contact Us	109

FEATURES AND SPECIFICATIONS

The QSDT8PCRC, QSDT8PCDP and QSDT16PCRP 8- and 16-Channel cards allow you to add surveillance capabilities to your computer. They use a H.264 hardware compression format which provides maximum file storage with the least amount of signal loss possible. Monitor and record up to four channels in CIF resolution with synchronous audio and video compression and transmission. Remotely monitor your system through your network, over the Internet or using select mobile devices.

The first chapters will cover the installation of your card as well as any connections you may wish to make. Later chapters will guide you through the installation of the SuperDVR 6.3 software which supports these cards along with how to operate the hardware and software together.

Please make sure you operate the products strictly in accordance with applicable laws along with following the guidance of this manual to maintain the stability of your digital surveillance system.

This product offers the following features:

Motion detection mode

Motion detection areas are adjustable with a maximum 16 areas for each channel. Users can also set motion detection sensitivity for each channel. The system begins to record only when motion is detected on the channel and after motion stops it will stop recording after a certain time period, which is adjustable by users.

Sensor alarm record mode

The system has an external alarm dongle which enables the system to support alarm input and output.

Recycling record mode

Users can set recording storage sequence for hard drive partitions. The recording storage will automatically switch to the next partition when the current one is full. If all the partitions are full and recycling record mode is enabled, the oldest recorded data will be covered by new data. Users can also set hard drive minimum storage alarm. Then once the present storage space is less than the minimum storage and recycling record mode is not enabled, recording will automatically stop.

P.T.Z control function

Supports many protocols: PelcoD, PelcoP, DSCP, DH-SD, Lilian, Minking, Neon, Star, VIDO, and VISCA. Users can control multiple speed domes and integrative cameras, including pan, tilt, zoom, focus and iris adjustment for P.T.Z devices. Supports preset points and auto scan.

User management

Different users have different rights, user names and passwords, to ensure system security.

Multi-channel display

Supports different multi-channel display modes, full screen display and auto dwell display.

Also:

- One PC can fit 1, 2 or 4 cards of the same model to control up to 32 channels total
- Supports 320x240, 704x480 (NTSC), 352x288, 704x576 (PAL) standard resolutions.
- Image color is adjustable for each channel, including contrast, brightness, hue and saturation.
- H.264 compression format greatly reduces HDD usage.
- Powerful video playback functions, including pause, stop, fast-forward, single-frame play and image capture.
- Supports advanced search mode. Users can search by date/time, camera, record mode, and random combination of the three methods.
- Supports recorded file backup, delete by date/time, camera.
- Conveniently extend system functions through software upgrades.
- Supports multiple languages, including English, German, Spanish, Portuguese, Chinese (Traditional), and other customized languages.
- CPU and storage resource saving by advanced technology
- Remote Surveillance and P.T.Z control through LAN, Intranet, and Internet.
- Supports alarm pre-record.
- Supports buzzer, e-mail alarm out.
- Can greatly decrease fragmented files while using NTFS partition.
- User-friendly graphical user interface.

SYSTEM REQUIREMENTS AND SPECIFICATIONS

2.1 SYSTEM REQUIREMENTS



NOTE! If recorded disk partition's format is FAT32 and the system has run for a long time, the system will create a lot of data fragments that may result in system running slowly. It's recommended to run a disk defragmenter every 10 to 30 days. We strongly suggest that you use NTFS format for recording disk partition.

QSDT8PCRP & QSDT8PCDP

PC Module	Card	Single QSDT8PCRC or QSDT8PCDP card	Two QSDT8PCRC or QSDT8PCDP cards
CPU		Intel P4 2.8Ghz minimum or later Intel processor	Intel Dual-core 2.8Ghz minimum
Motherboard		Intel with Intel system chipset	
Hard Drive		500GB minimum	
RAM		1GB minimum	2GB minimum
Video Card		Supports MOST* AGP and PCI-E Video Cards with 256MB of RAM or more with full Direct Draw support. *Some newer PCI-E cards are not yet supported	
OS		Win 2000(SP4 above) /Win XP(SP2 above) /VISTA/Win7	
DirectX		9.0	

QSDT16PCRP

PC Module	Card	Single QSDT16PCRC card	Two QSDT16PCRC cards
CPU		Intel P4 2.8Ghz minimum or later Intel processor	Intel Dual-core 2.8Ghz minimum
Motherboard		Intel with Intel system chipset	
Hard Drive		500GB minimum	
RAM		1GB minimum	2GB minimum
Video Card		Supports MOST* AGP and PCI-E Video Cards with 256MB of RAM or more with full Direct Draw support. *Some newer PCI-E cards are not yet supported	
OS		Win 2000(SP4 above) /Win XP(SP2 above) /VISTA/Win7	
DirectX		9.0	



NOTE! We do not recommend AMD systems because the SuperDVR program usually has problems communicating with the video card on the system through the chipset on the AMD motherboard. There are often similar problems with Intel processors on motherboards that use chipsets other than Intel, and there are known issues with the Intel G31 chipset.

2.2 SYSTEM SPECIFICATIONS

- Format: NTSC /PAL
- Resolution
 - QSDT8PCRP & QSDT16PCRP: 320x240 @ 30FPS (NTSC) / 352x288 @ 25FPS (PAL) / 704x480 @ 7FPS (NTSC) / 704x576 @ 6FPS (PAL)
 - QSDT8PCDP: 704x480 @ 30FPS (NTSC) / 704x576 @ 25FPS (PAL)
- Screen set: resolution 1024x768, color quality 16 bits or 32 bits.
- Compression format: H.264 Hardware
- Compression code rate: 50kbps – 1.2Mbps.
- Data format: H.264 (files saved as AVI)
- Input: D type connector
- PTZ: Protocol Configurable, Remote Control Capability
- Remote Access Software: Internet Explorer
- Interface: PCI

VIDEO CAPTURE CARD HARDWARE AND CONNECTIONS

3.1 QSDT8PCDP CARD

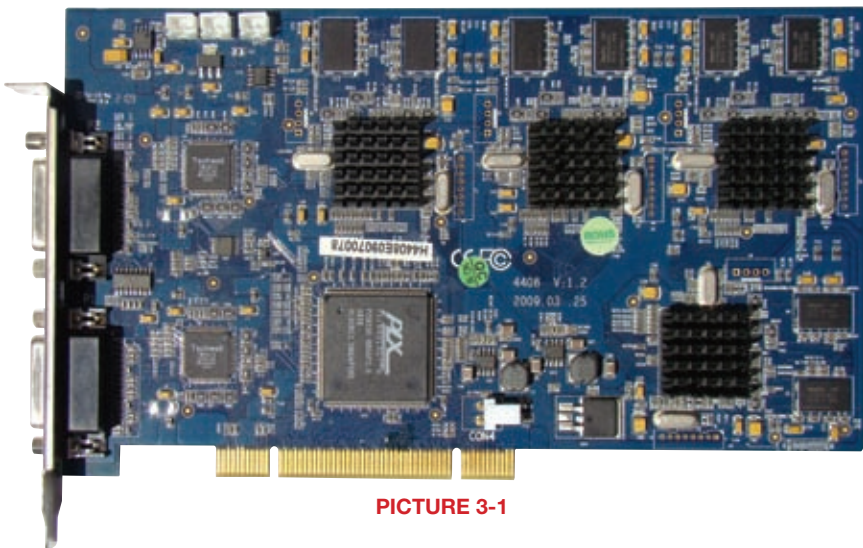

PICTURE 3-1

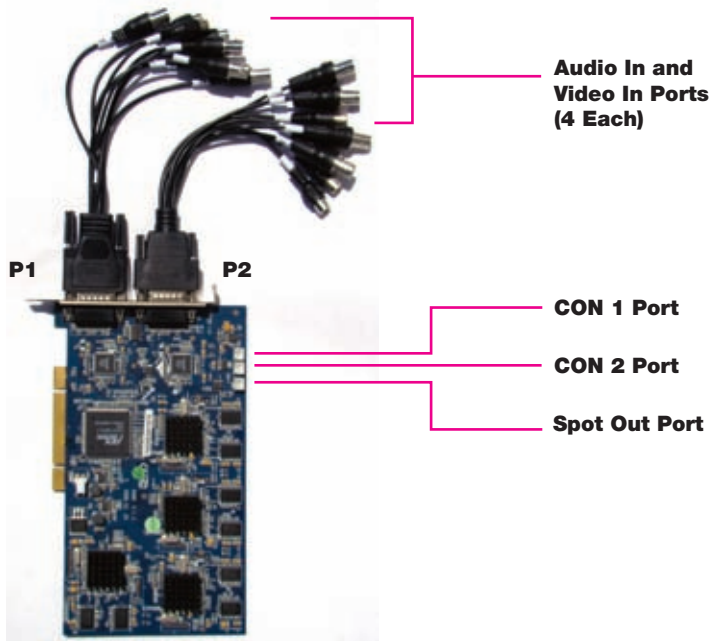

PICTURE 3-2

VIDEO AND AUDIO PIN LAYOUT

P1

Pin	Connection
1	VIDEO-5
2	GND
3	VIDEO-6
4	GND
5	VIDEO-7
6	GND
7	VIDEO-8
8	GND
9	GND
10	AUDIO-5
11	AUDIO-6
12	AUDIO-7
13	AUDIO-8
14	NULL
15	GND

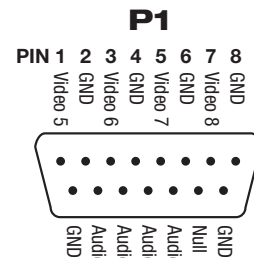

PIN 9 10 11 12 13 14 15

P2

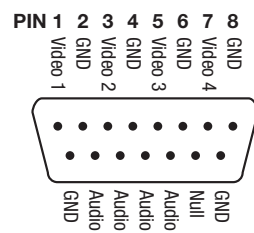

PIN 9 10 11 12 13 14 15

P2

Pin	Connection
1	VIDEO-1
2	GND
3	VIDEO-2
4	GND
5	VIDEO-3
6	GND
7	VIDEO-4
8	GND
9	GND
10	AUDIO-1
11	AUDIO-2
12	AUDIO-3
13	AUDIO-4
14	NULL
15	GND

PICTURE 3-3

CONNECTING MULTIPLE CARDS

You may control up to 32 cameras by installing up to four QSDT8PCDP cards. You will need to connect the cards in the manner shown below to use the Spot Out option.

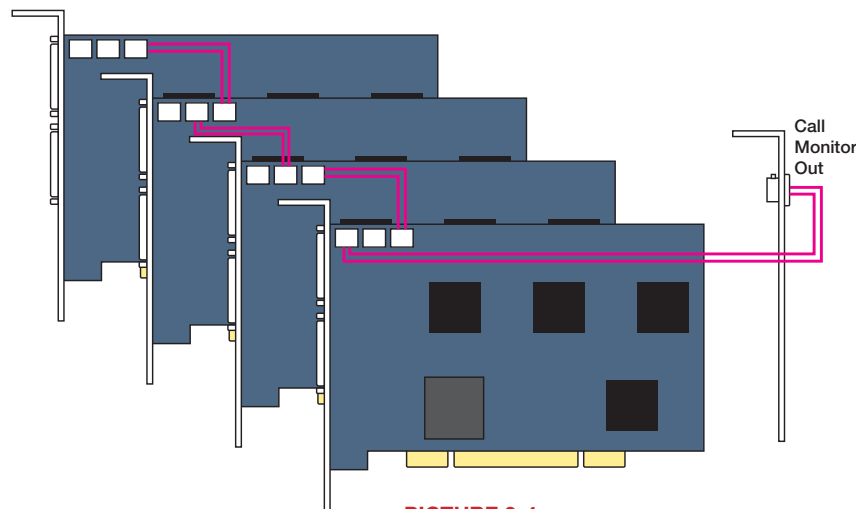

PICTURE 3-4

3.2 QSDT8PCRP CARD

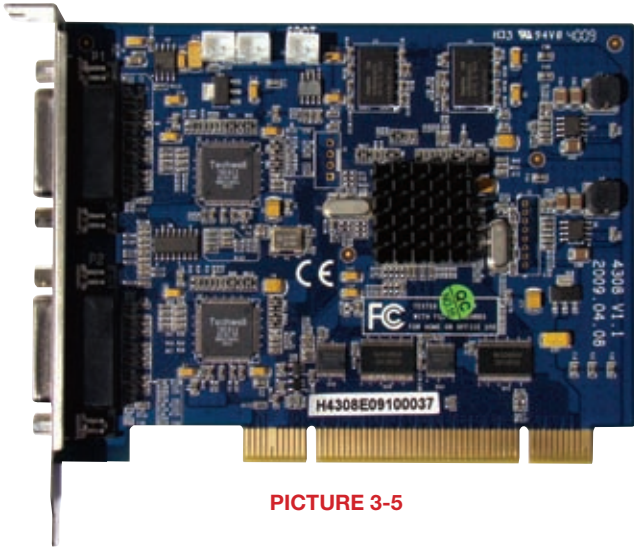

PICTURE 3-5

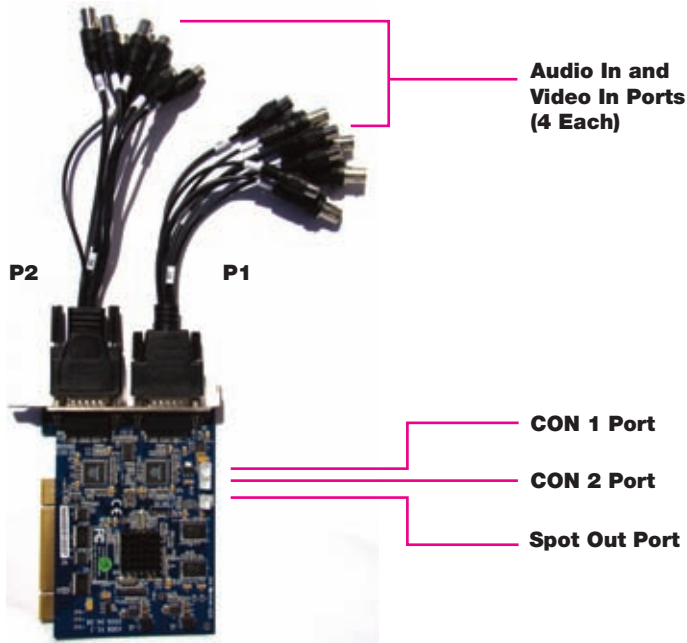

PICTURE 3-6

VIDEO AND AUDIO PIN LAYOUT

P1

Pin	Connection
1	VIDEO-5
2	GND
3	VIDEO-6
4	GND
5	VIDEO-7
6	GND
7	VIDEO-8
8	GND
9	GND
10	AUDIO-5
11	AUDIO-6
12	AUDIO-7
13	AUDIO-8
14	NULL
15	GND

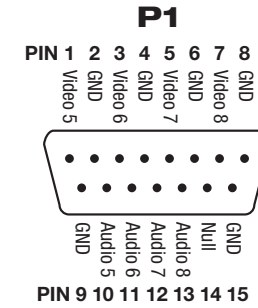

P2

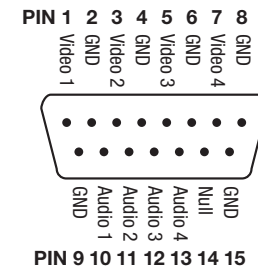

PICTURE 3-7

P2

Pin	Connection
1	VIDEO-1
2	GND
3	VIDEO-2
4	GND
5	VIDEO-3
6	GND
7	VIDEO-4
8	GND
9	GND
10	AUDIO-1
11	AUDIO-2
12	AUDIO-3
13	AUDIO-4
14	NULL
15	GND

CONNECTING MULTIPLE CARDS

You may control up to 32 cameras by installing up to four QSDT8PCRP cards. You will need to connect the cards in the manner shown below to use the Spot Out option.



PICTURE 3-8

3.3 QSDT16PCRP CARD

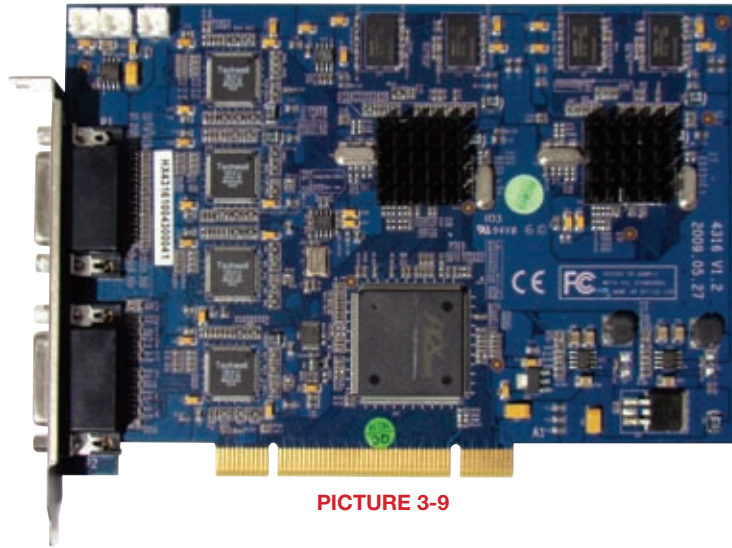

PICTURE 3-9

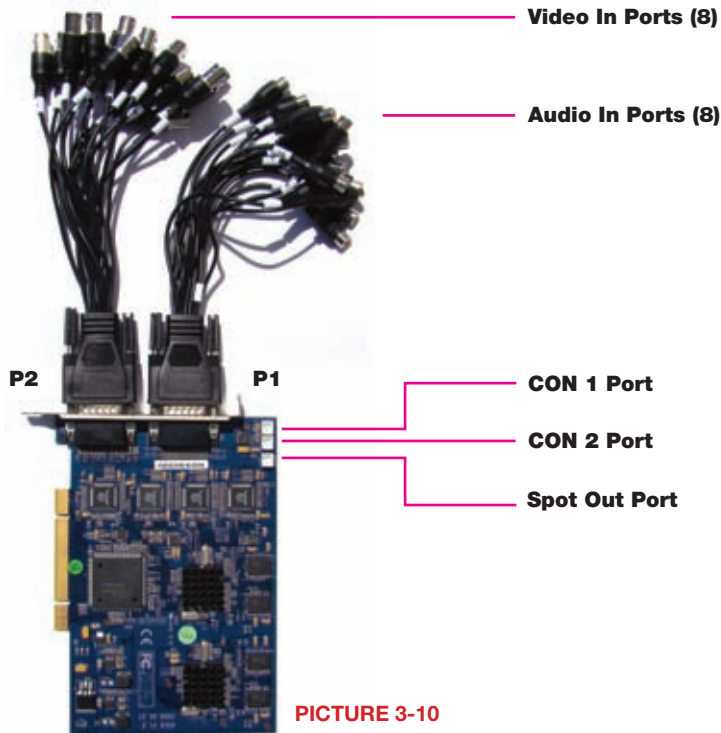

PICTURE 3-10

VIDEO AND AUDIO PIN LAYOUT

P1

Pin	Connection	Pin	Connection
1	AUDIO2	11	AUDIO3
2	AUDIO4	12	AUDIO5
3	AUDIO6	13	AUDIO7
4	AUDIO8	14	AUDIO9
5	AUDIO10	15	AUDIO11
6	AUDIO12	16	AUDIO13
7	AUDIO14	17	NULL
8	AUDIO15	18	NULL
9	AUDIO16	19-26	GND

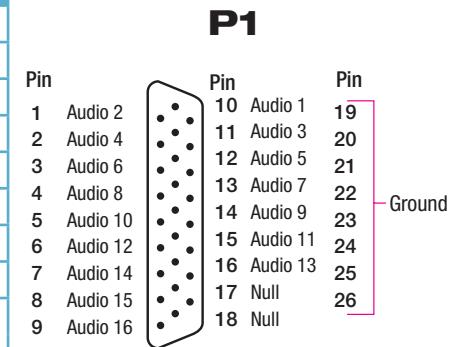

P2

Pin	Connection	Pin	Connection
1	VIDEO2	11	VIDEO3
2	VIDEO4	12	VIDEO5
3	VIDEO6	13	VIDEO7
4	VIDEO8	14	VIDEO9
5	VIDEO10	15	VIDEO11
6	VIDEO12	16	VIDEO13
7	VIDEO14	17	NULL
8	VIDEO15	18	NULL
9	VIDEO16	19-26	GND
10	VIDEO1		

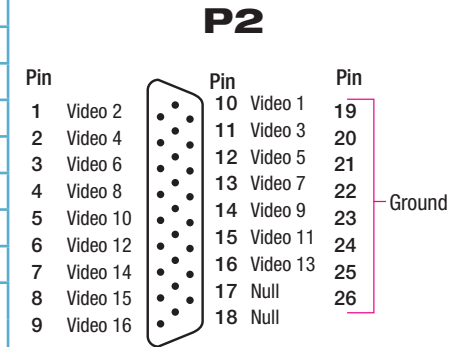

PICTURE 3-11

CONNECTING MULTIPLE CARDS

You may control up to 32 cameras by installing up to two QSDT16PCRP cards. You will need to connect the cards in the manner shown below to use the Spot Out option.

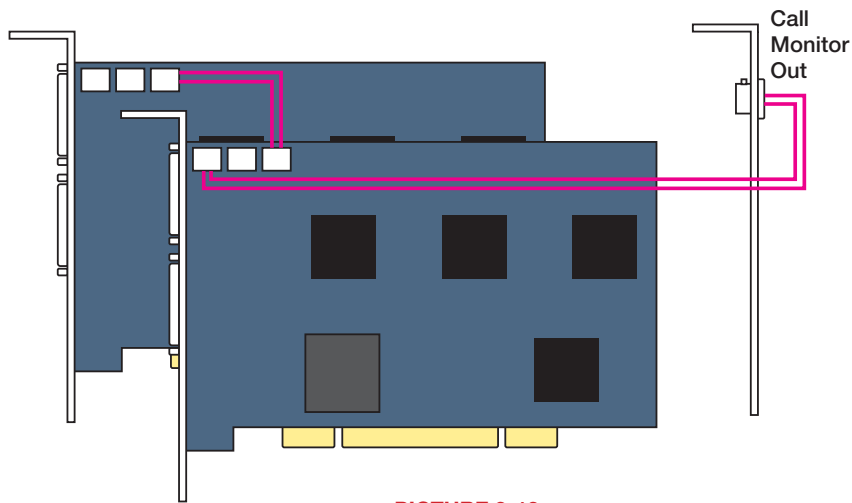

PICTURE 3-12

3.4 CONNECTING A PTZ CAMERA

In order to operate a PTZ camera from your card, you will need to have first installed the card into a PCI slot within the computer and attached the video dongle.

You will also need an RS485 to RS232 (Serial) adapter as well as having a serial port on the back of your PC.

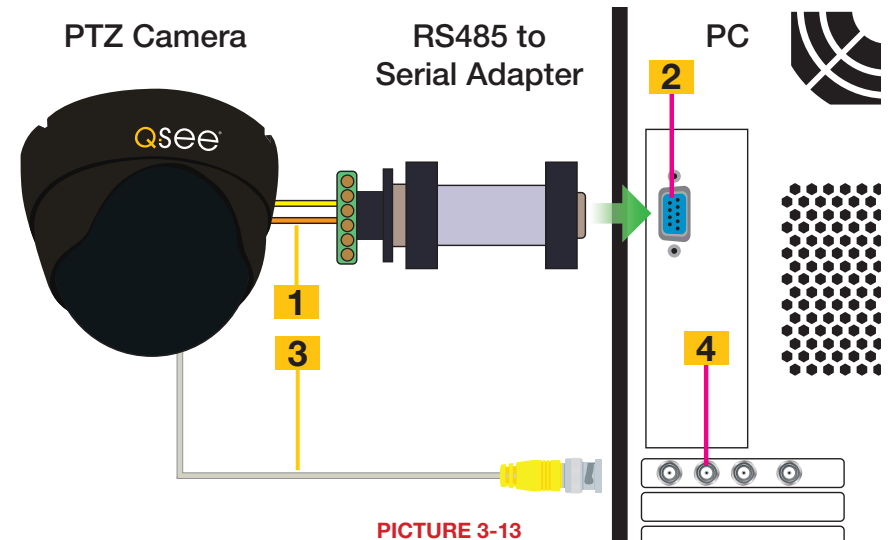

PICTURE 3-13

STEP 1. Connect the RS485 cables from the PTZ camera to the RS485-to-Serial Adapter

STEP 2. Connect the Adapter to the serial port on the back of the PC

STEP 3. Connect the video line from the camera to any Video In port on the DVR card (Item 4)

You may now connect your camera to a power source.

Please see **Chapter 8** for instructions on operating the PTZ camera with the SuperDVR software.

INSTALLING THE SUPERDVR SOFTWARE

4.1 INSTALLING THE SOFTWARE

You will be controlling your security system using the SuperDVR software. It is compatible with Windows 2000, XP, and both the 32 bit and 64 bit versions of Vista and Windows 7.

The SuperDVR software is included on the disk that comes packaged with your DVR card. It can also be downloaded from our website at www.Q-See.com by simply searching for your product and going to the Downloads section.

STEP 1. The software can be installed from the CD by selecting the appropriate button in the CD's menu, by copying the installer to your hard drive and then double clicking to begin the process.



PICTURE 4-1

STEP 2. Once the **Setup** window opens, click **Next** to begin the installation.

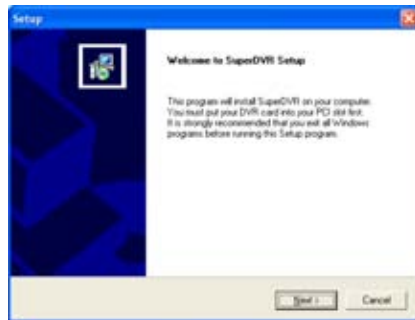

PICTURE 4-2

STEP 3. Select your video format. NTSC is the standard in North America. Click **next** to continue.

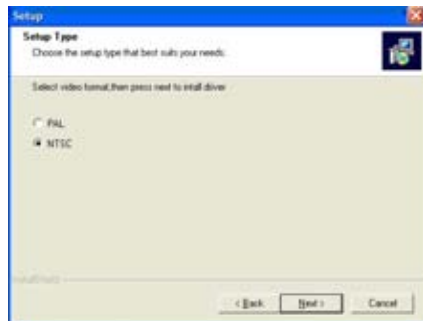

PICTURE 4-3

STEP 4. Instruct the installer where you want the software to be placed. Either use the default location or select your own. Click **Next** to continue.

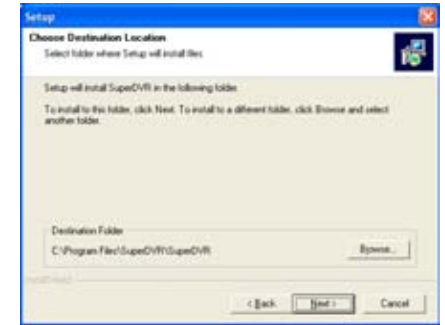

PICTURE 4-4

STEP 5. Once the installation has completed, you will be asked to press the **Finish** button.

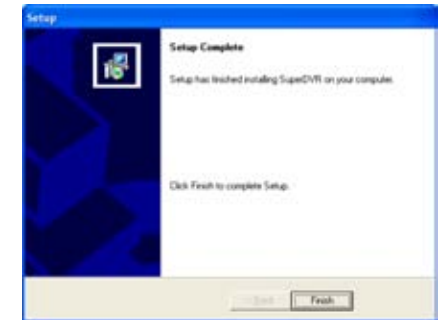

PICTURE 4-5

As part of the installation process, a shortcut to the SuperDVR software will be placed on your desktop.

You will need to restart your computer before you can launch SuperDVR and begin setting up your surveillance system.



PICTURE 4-6

4.2 USER ACCOUNT CONTROL FOR WINDOWS VISTA AND WINDOWS 7

Some users of computers using Windows Vista or Windows 7 operating systems may receive an error message informing of a codec that is missing or not installed. This conflict can be resolved by turning off User Account Control (UAC).

Windows Vista

1. Open the Control Panel (accessible by clicking on the Windows icon in the lower left of your screen).

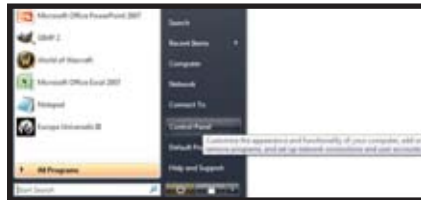

PICTURE 4-7

2. Select **User Accounts and Family Safety**.

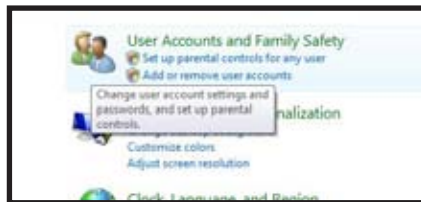

PICTURE 4-8

3. Select **"Add or Remove User Account."**

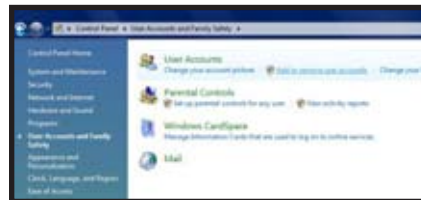

PICTURE 4-9

4. Select the desired user account.



PICTURE 4-10

5. Select **Turn User Account Control on or off**

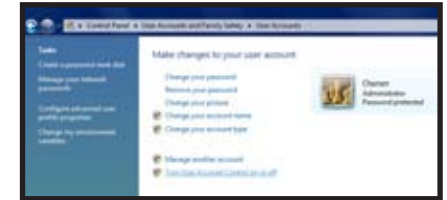

PICTURE 4-11

6. Uncheck the box next to "Use User Account Control (UAC) to help protect your computer."



PICTURE 4-12

7. You will then be asked to restart your computer for the change to take effect.

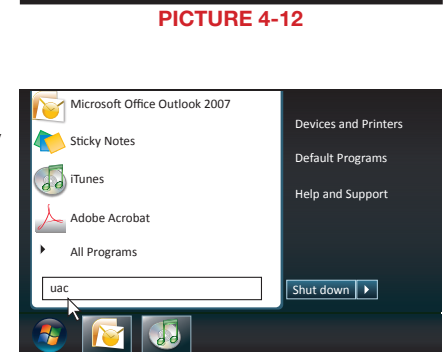

PICTURE 4-13

Windows 7

1. Open up the Start Menu (accessible by clicking on the Windows icon in the lower left of your screen).

2. Type "uac" into the search bar and hit **ENTER**. The User Account Control will open or you will be offered a link to click to open it.

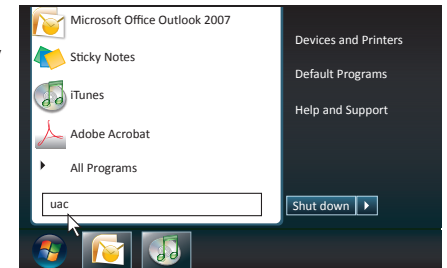

PICTURE 4-13

3. Move slider to lowest setting and press **OK**.

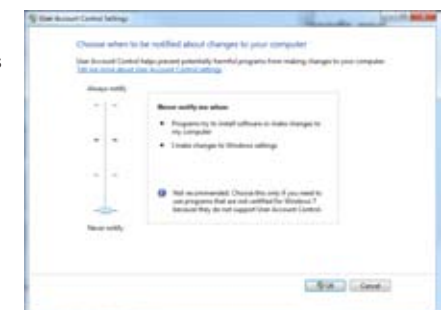

PICTURE 4-14

When you launch the SuperDVR program, it will open to the **Main Display Interface** which will show the video feeds from the cameras as well as the **Display Control Panel**.



PICTURE 5-1

No.	Item	No.	Item
1	Display Window	2	Record Status Panel
3	Display Modes	4	Display Control Panel
5	Dwell Time	6	Page Flip
7	Drive Capacity Indicator Bar	8	Snapshot
9	Urgent Record	10	Date and Time
11	Login	12	Emap
13	Search and Playback	14	Configurations
15	PTZ Control	16	Exit

5.1 LOG IN

Located on the left side of the **Main Display Interface**, clicking on the lock icon will open the **Login** window. Enter your user name and password to access the controls. The default user name is **System** with no password required. You can add a password and create other user accounts as described in **Section 7.4 User Configuration**.

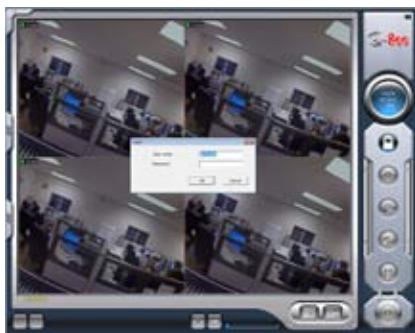

PICTURE 5-2

5.2 DISPLAY CONTROL PANEL

The Display Control Panel includes the Display Mode buttons along with buttons which allow you to cycle automatically or manually through individual or groups of channels.

Buttons currently in effect are highlighted.

The Drive Capacity Indicator Bar will fill in as more files are recorded to the drive. When the drive is at capacity, the bar will be red.



PICTURE 5-3

DISPLAY MODES

Choose the number of channels you wish to view simultaneously. If you have fewer cameras than portions of the screen, those channels without cameras will remain black.

Available modes are single-, four-, nine-, 16- and 36-screen displays. The software will only display the modes appropriate to the number of cameras you have connected.



PICTURE 5-4

AUTO DWELL DISPLAY

If the **Main Display** is currently showing fewer channels than are available, you can have the DVR automatically cycle through and show the feed from each camera or group of cameras by selecting the button.

PAGE FLIP

This button allows you to manually cycle through the channels. Like the Auto Dwell feature, if there are more channels available than are currently being displayed in a multi-screen display mode, this button will take you to the next group of video feeds.

5.3 OTHER CONTROLS

Log In will be covered in the following section and the remaining operations on the left hand side of the **Main Display Interface** will be covered in **Chapter 7**. The two remaining functions are **Snapshot** and **Urgent Record**.

SNAPSHOT

Usable in single image display mode, pressing this button will take a series of still images from the camera currently being displayed and will save them to a location on the hard drive. Settings to determine the number of images (up to 32) as well as the location to where they will be saved will be covered in **Chapter 6**.

URGENT RECORD

Clicking the Urgent Record icon will cause all cameras to begin recording regardless of their schedule or recording mode. Video will be saved to the location designated by the user. Like Snapshot, the settings for this feature will be covered in **Chapter 6**.

RECORDING, PLAYBACK AND RECORD SEARCH

6.1 RECORDING CONFIGURATION

The system can be set to record in four different modes; scheduled recording, manual recording, motion detection and sensor alarm.

Once you have logged into your system, you can access the control settings through the **Configuration** window by clicking on the wrench icon located on the left of the **Main Display Interface**.

Upon accessing the **Configuration** window, the icons on the left will change as will the contents of the **Display Window**.



PICTURE 6-1

	Basic Configuration		Schedule configuration
	Video configuration		Motion Detection Configuration
	Alarm Configuration		P.T.Z Configuration
	User Configuration		Save and Return

For the purposes of this chapter, we will only be concerned with; Schedule Configuration, Video Configuration and Motion Detection Configuration. The remaining functions will be covered in **Chapter 7**.

BASIC CONFIGURATION

The Record Panel, in the bottom half of the Basic Configuration page, allows users to set recording modes along with other parameters for each camera. More than one recording mode can be activated at one time.

It should be noted that the higher the recording quality and frame rate, the more space the recorded file(s) will occupy on the hard drive.

	CAM1	CAM2	CAM3	CAM4	CAM5	CAM6	CAM7	CAM8
Name	CAM1	CAM2	CAM3	CAM4	CAM5	CAM6	CAM7	CAM8
<input type="checkbox"/> Time Stamp	<input type="checkbox"/>	<input type="checkbox"/>	<input type="checkbox"/>	<input type="checkbox"/>	<input type="checkbox"/>	<input type="checkbox"/>	<input type="checkbox"/>	<input type="checkbox"/>
<input type="checkbox"/> Switch	<input type="checkbox"/>	<input checked="" type="checkbox"/>	<input checked="" type="checkbox"/>	<input type="checkbox"/>	<input checked="" type="checkbox"/>	<input checked="" type="checkbox"/>	<input checked="" type="checkbox"/>	<input checked="" type="checkbox"/>
<input type="checkbox"/> Manual Record	<input type="checkbox"/>	<input type="checkbox"/>	<input type="checkbox"/>	<input type="checkbox"/>	<input type="checkbox"/>	<input type="checkbox"/>	<input type="checkbox"/>	<input type="checkbox"/>
Manual Record Frame Rate	6	6	6	6	6	6	6	6
<input type="checkbox"/> Schedule Record	<input type="checkbox"/>	<input type="checkbox"/>	<input type="checkbox"/>	<input type="checkbox"/>	<input type="checkbox"/>	<input type="checkbox"/>	<input type="checkbox"/>	<input type="checkbox"/>
Schedule Record Frame Rate	3	3	3	3	3	3	3	3
<input type="checkbox"/> Motion Detection	<input type="checkbox"/>	<input checked="" type="checkbox"/>	<input checked="" type="checkbox"/>	<input type="checkbox"/>	<input type="checkbox"/>	<input type="checkbox"/>	<input type="checkbox"/>	<input type="checkbox"/>
Motion Record Frame Rate	6	3	6	6	6	6	6	6
Sensor Record Frame Rate	6	6	6	6	6	6	6	6
<input type="checkbox"/> Camera Security	<input type="checkbox"/>	<input type="checkbox"/>	<input type="checkbox"/>	<input type="checkbox"/>	<input type="checkbox"/>	<input type="checkbox"/>	<input type="checkbox"/>	<input type="checkbox"/>
Record Quality	medium	lower	medium	medium	medium	medium	medium	medium
Audio In	None	None	None	None	None	None	None	None

PICTURE 6-2

Time Stamp - By selecting this option, the record date / time message appears in the recorded file images.

Switch - Turns on corresponding cameras. If there is no camera on a channel, do not select this option and you will save system resources.

Manual Record - Images from the selected camera will be recorded and saved all the time (24 hour recording).

Manual Recording Frame Rate - Select the recording frame rate for manual record mode.

Schedule Record - This option allows you to record on a set schedule.

Schedule Record Frame Rate - Select Schedule Recording frame rate.

Motion Detection - By selecting this option, users can set the selected channels to record when motion is detected in front of the camera.

Motion Record Frame Rate - Select recording frame rate for Motion Detection record mode.

Sensor Record Frame Rate - If sensors are utilized to trigger recording, users can select recording frame rate here.

Camera Security - Users are divided into three types: Normal user, Power user and Administrator. By selecting this option, only administrators can see the selected channels.

Record Quality - Select recording image quality here.

Audio In - SuperDVR 6.3 can support one channel of microphone audio input signal on the PC motherboard and any audio inputs that are on the card if any. Users can choose one video channel for each available audio input.

RECORD STATUS PANEL

A series of indicator lights will convey the recording status of each attached camera.



PICTURE 6-3

	Grey	Normal		Light Green	Manual Record
	Dark Green	Schedule Record		Yellow	Motion Detection Record
	Red	Sensor Alarm Record		Blue	Video Loss State

If an indicator light color turns, it means there is an alarm output.

6.2 RECORDING MODES

As mentioned at the beginning of this chapter, there are four different recording modes; scheduled recording, manual recording, motion detection and sensor alarm. Motion Detection record mode and Sensor Alarm record mode are called Alarm Record.

If users use multiple cameras to record, every camera works separately and the recorded files are also saved separately. The parameters, i.e. camera ID, record date/time, and record mode are all saved together with the recorded file.

MANUAL RECORD MODE

Manual Record mode is the most commonly used recording mode. If a special event occurs, users can select this recording mode and record immediately. It may be desirable to increase the framerate and recording quality in such cases - especially for shorter duration recordings. If you intend to have the cameras recording non-stop, then it is advisable to reduce the frame rate to conserve hard drive space.

SENSOR ALARM RECORD MODE

Users can use sensors to trigger sensor alarm recording on relative channels. At that time, the record status indicator light will turn red.

MOTION DETECTION RECORD MODE

This will enable the system to detect image changes and begin to record by activating motion detection and motion alarm recording. For instance, somebody opens the door, and the system detects image changes from the camera and begins to record, then users can play back the recorded file and find out who opened the door. When there is no movement, the system will not record which saves system resources, and makes it easier to find recorded events. The indicator light color in the record status panel will be yellow.



NOTE! When configuring for Motion Detection recording, you will need to do so in three areas:

1. Select **Motion Detection** for the desired channels in **Basic Configuration**.
2. Configure the specific areas to detect motion in **Motion Detection Configuration**.
3. Set the schedule for these cameras to operate in this mode in **Schedule Configuration**.

Configuring Motion Detection



Selecting the running man icon will bring up the Motion Detection Configuration page, where you can configure the settings for each camera according to your situation.

Sensitivity - Users can set motion detection sensitivity here.

Speed - Motion detection speed

Block Number - Set grid's number.

Defaults - Reset to default settings.

Select All - Select the entire area of the channel as detection sensitive

Clear - Clear all the detection areas and then you can select a customized detection area using the cursor.



PICTURE 6-4

To customize the detection area for a certain channel:

STEP 1. Select the camera in the pull down list.

STEP 2. Select **Clear**

STEP 3. Click and drag the cursor in the camera view. You will see a green box appear which shows the motion detection area. You can select a maximum of 16 customized areas for each channel.

SCHEDULE RECORDING

Users can set working schedule for all of the recording modes in 'Schedule Configuration'. The dark green light in record status panel shows the corresponding channel is in Schedule Record mode. Users can change record mode to manual record at any time, and the dark green light will change into a light green light.

Schedule Configuration



Clicking on the calendar icon will change the display window to the Schedule Configuration page.

Each camera can be scheduled to record based on motion detection, sensor alarm, and time of day. Sensor alarm mode has highest priority and it will take precedence regardless of what other modes the camera is also set for.



PICTURE 6-5

Schedules can be set individually for each day. The cameras are default configured to be recording in both Motion Detection and Schedule recording 24/7 and will have full-length colored bars in the schedule window. Above each window is a 0-24 with segments corresponding to each hour of the day. This will show when a camera has been scheduled to record in that mode.

 **NOTE!** When setting up your recording schedule for the first time, it is faster and easier to begin by selecting the mode's schedule window and selecting **Delete All** to clear the schedule before making changes.

To create a new schedule;

STEP 1. Select the camera name in one of the three record mode groups.

STEP 2. Click on **Add**.



PICTURE 6-6

STEP 3. This will open a new window.

Set the start time and end time along with the day(s) to which you wish the schedule to apply.

STEP 4. Click **OK** to exit the **Add** window.



PICTURE 6-7

Your new schedule will appear as a series of colored bars corresponding to the day(s) and time(s) you've selected.

To edit a schedule, select a block of time and click **Edit**. You will be able to adjust the schedule for that day and any other day in the same manner you used to create the schedule in the **Add** window.

 **NOTE!** When adding a new schedule, it should not duplicate an existing schedule as this may cause a system error.

To add another block of time, such as an evening recording schedule to go with an early morning schedule, you will need to repeat the process.

Clicking on **Delete** will remove a specific block of time from a specific day's schedule.

Copy To allows you to apply the settings for one camera to another camera as well.

6.3 RECORDING TO HARD DRIVE

Users can determine where recorded files will be saved on their hard drive(s). In addition, the recorder can save to a series of drives or partitions by automatically jumping to the next partition when the current one is full. If all the partitions are full and **Recycling Record** mode has been enabled prior to recording by checking the box below the **Storage Disk** list, the new data will overwrite the oldest recorded data automatically.

The destination drive(s) for recordings - which also applies to images captured using the **Snapshot** button - is set in the **Basic Configuration** window. You can also set a HDD minimum storage alarm which will cause the system to alert you once the that threshold has been reached. If the present storage space is less than the minimum storage needed and Recycling Recordings is not selected, the recording will automatically stop.

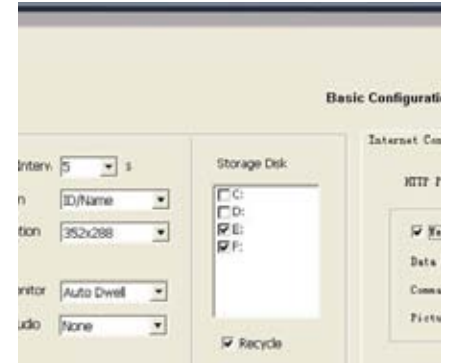

PICTURE 6-8

 **WARNING!** You should have your files record to a disk or partition OTHER than your "C" drive. This will avoid issues with the Recycling function.

6.4 RECORD SEARCH AND PLAYBACK

Clicking the Search icon in the lower right of the **Main Display Interface** will cause it to switch to the **Search and Playback Interface**. This interface handles both the Record Search and Playback functions in addition to allowing you to back up your records.



PICTURE 6-9

Pressing the back arrow in the upper right of the display will return you to live surveillance in the **Main Display Interface**.

RECORD SEARCH

Searches are based on date and time. Additional criteria can be selected to narrow the search. These criteria include the type of the recording and where the files are saved.

STEP 1. Select whether the program should search in the normal destination location (See **Section 6.3 Recording to Hard Drive**) and/or where you've backed up recorded files (Covered in **Section 6.5 Other functions**)

STEP 2. Select the nature of the recording - whether it was a scheduled record, recorded as a result of motion detection or etc. You can select more than one category.



PICTURE 6-10

STEP 3. Enter the date and time. A calendar will pop up. If there was an event recorded on that date it will be highlighted.



PICTURE 6-11



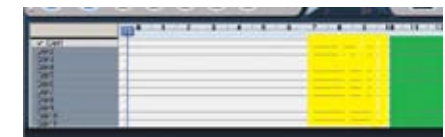



STEP 4. The program will display the search results at the bottom of the screen. They will be color coded to indicate the mode in which they were recorded.



PICTURE 6-12

PLAYBACK

Once you have completed your search, you are ready to play back your files. The controls on the **Search and Playback Interface** operate like any other video playback software.

Button	Function	Note
	Play / Pause	
	Stop	
	Reverse	Only functional when playing back in single channel mode.
	Previous Section	
	Next Section	
	Previous Frame.	Only functional when playing back in single channel and in Pause mode.
	Next Frame.	

By default, the system will begin playing back the recording from Channel 1 when the **Play** button is pressed.

Selecting a **Screen Display Mode** button above the file list will open a pop-up window allowing you to select which channel(s) to play back. Only the screen display mode buttons appropriate to your card will be offered as options. Buttons allowing you to select specific groups of channels will appear depending on your card's capabilities. Click **OK** to return to the Playback window.



PICTURE 6-13

During playback, you can adjust the speed of the recording with the **slider** located at the bottom of the interface.



PICTURE 6-14

In addition, you can advance the playback to a certain point in the record by clicking on, and sliding the progress indicator.

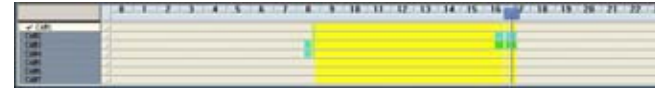

PICTURE 6-15

At the top of the file visualizer, the bar represents the time when the file was recorded. Clicking on this will magnify it to show minutes allowing a more precise search.



NOTE! Clicking on any channel in multi-screen playback will switch the display to a single-channel view of that feed. Click again to return to the previous playback mode.

6.5 OTHER FUNCTIONS

Other functions within this interface allow you to back up files, capture still images, print images and digitally zoom in on a recording.

FILE BACKUP

 Clicking on the file icon allows you to back up your files to another drive for use elsewhere or simply to preserve them without having to worry about them being overwritten by the Recycling Record function.

The **Backup** window operates much like the **Record Search** window and it is divided into four main areas:

A: Camera Selection Area - Select which cameras' recordings you wish to back up.

B: Time and Date Selection Area - Select the start and end dates and times for the records you wish to back up.

C: Operation Area - Select the save path for the backup files. You can also choose to save a standalone playback program to allow others to view the files.

D: Information Area - The program will use this area for any warnings or notices.

Click **Start** to begin backing up your files.



PICTURE 6-16

DELETING RECORDED FILES

While older files will get overwritten by the Recycling Recording function as the hard drive fills up, you can delete unnecessary or unwanted recordings before then.

This function will delete a file or blocks of files from a specific camera or which were recorded during a set time.

Select the channel on the left side, and then select start date and time and end date and time of the files you wish to delete.

Click **Start** to delete files.

You can also remove files manually by deleting them from the folder where they are stored, just as with any other PC file.



PICTURE 6-17

CAPTURE PICTURES

This feature allows you to capture still images from a recorded event so they can be saved or printed out.

When the **Search and Playback Interface** is displaying only a single channel and the user hits the **Play/Pause** button a second time to pause playback, then the video is in **Playback Pause** mode.

At this time the function buttons above the **File Search** panel will be enabled.



PICTURE 6-18

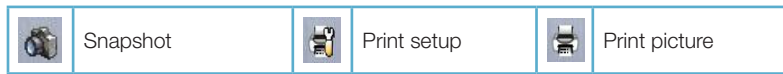

NOTE! This feature is only available in Playback Pause mode on a single channel.

In addition, a second menu will appear below the Search panel. This allows you to make picture quality adjustments for the present channel, including brightness, contrast, saturation and hue.

These changes will not affect the actual recorded image. Pressing the **Default** icon in the lower right of the panel will restore the original settings.

Make the desired adjustments to the image and then select the **Snapshot** icon.



PICTURE 6-19

Pressing the Snapshot button will bring up the **Snap** window.



PICTURE 6-20

Select the number of sequential images you wish to capture and set the save path. The save path can also be set in the Basic Configuration menu in the **Capture Browse** setting. You can also choose to include which camera took the video and/or the date and time that it was recorded within the image itself.

Once you have made your selections, pressing the **Snap** button will save the images. Press **Save** to preserve your settings for future use or **Exit**, if you do not wish to retain the settings.

The Print Setup button will bring up a conventional Print Setup window to allow you to make settings as normal.

Clicking the Print button will open a Print Preview dialog that includes some extra features.

Select the **Position** radio button and adjust the position of the image on the page using the + and - buttons.

Selecting the **Size** radio button will allow you to adjust the image size using those same + and - buttons.



PICTURE 6-21

DIGITAL IMAGE ZOOM

During multi-screen playback, clicking on one channel will cause the display to shift to a single channel display mode.

While in single channel playback mode the digital zoom controls are enabled. These allow you to zoom in or out of an area of the recording.



PICTURE 6-22

	Zoom In
	Zoom Out
	Revert to original size

SYSTEM SETTINGS

Beyond the recording settings, there are other features of this video capture card which need to be enabled or configured.

The Settings window is entered by clicking on the wrench icon on the left of the **Main Display Interface**.



PICTURE 7-1

	Basic Configuration		Schedule configuration
	Video configuration		Motion Detection Configuration
	Alarm Configuration		P.T.Z Configuration
	User Configuration		Save and Return

7.1 BASIC CONFIGURATION

Your card is pre-configured with default settings which meet the needs of most users, however it is designed to allow you maximum flexibility in configuring the system to meet your specific needs.

In the upper portion of the Basic Configuration window are settings which control additional aspects of your cameras. We have already covered the recording-specific settings in the previous chapter.

CAMERA DISPLAY SETTINGS

Dwell Interval

If you have enabled Auto Dwell function on the main interface page, then you can set the dwell time, in seconds, of a screen here.

Caption

There are four options, None, ID, Name, and ID/Name for users to select for all the channels.

'None' means no title or name;

'ID' means camera numbers, i.e. 1, 2, 3 and so on;

'Name' means camera names, i.e. Cam1, Cam2 and so on;

'ID/Name' means both camera number and camera name, i.e. 1/Cam1, 2/Cam2 and so on.

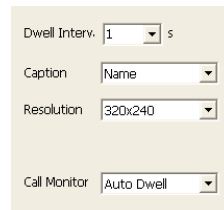

The screenshot shows a configuration window with four dropdown menus. The first is 'Dwell Interv.' with '1' selected and 's' to its right. The second is 'Caption' with 'Name' selected. The third is 'Resolution' with '320x240' selected. The fourth is 'Call Monitor' with 'Auto Dwell' selected.

PICTURE 7-2

Resolution

You may have resolution options of 320x240, 640x480, or 704x480 (NTSC) for users to select for all the channels depending on the card you are using.

Call Monitor

You can connect another monitor to the Spot Out port on the card and select the display modes here.

SYSTEM LOG IN AND REBOOT

You can enter your User Name and Password that you use to log into Windows so that the SuperDVR can log in upon startup or reboot.

Since the windows system may become unstable after a couple of days of continuous operating, it may cause SuperDVR to become unstable. You can use the software support auto-reboot option to help avoid this. Select the **PC Auto Reboot** tab in the center of the **Basic Configuration** screen and then check the box next to **PC Auto Reboot** and set the interval by day, which will cause the system to reboot automatically according to your schedule.

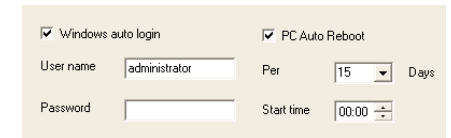

The screenshot shows a configuration window with two checked checkboxes: 'Windows auto login' and 'PC Auto Reboot'. Below these are four input fields: 'User name' with 'administrator', 'Per' with '15', 'Password' (empty), and 'Start time' with '00:00'. The 'Days' label is to the right of the 'Per' field.

PICTURE 7-3

VIDEO CONFIGURATION

Clicking on the video configuration icon will open a new page which will allow you to change the contrast, brightness, hue, saturation and auto gain of individual cameras, by moving the levers on the bars. Clicking **Default** will restore the default values.

The range of values is from 0 to 255.

Contrast - Set image color contrast.

Brightness - Set image brightness.

Hue - Set image hue.

Saturation - Set image Saturation



PICTURE 7-4

7.2 ALARM CONFIGURATION

The system can receive alarm signals generated both by attached devices as well as from those from over a network. Alarms can also be generated when motion is detected.



PICTURE 7-5

ALARM TYPES

Different conditions can be set to trigger an alarm.

Video Loss - Users can select alarm output for this option.

For example: If you select alarm_out1 and alarm_out3 for video loss. Then video loss of any channel will trigger alarm_out1, alarm_out3 to show a red light in the Alarm output status panel

Disk Alarm - When HDD available space is less than the set value, it will trigger alarm.

Sensor - If users have mounted sensors, when the sensors have been activated, it will trigger the selected output alarms.

Motion - Users can set the output of motion detection alarm by different alarms and remote alarm.

Users can also select the voltage (high or low) for alarm signals.



PICTURE 7-6

TRIGGERED ACTIONS

Each type of alarm can be configured to generate an audible alarm - externally or internally, as well as triggering other, pre-defined actions.



PICTURE 7-7

Buzzer - Select whether to activate the computer buzzer if alarms have been triggered and also select how long the buzzer sounds.

Pre-Alarm Record - Select whether the system will pre-record and for how long.

Big Screen Holding Time - The corresponding channel will be full screen when an alarm is triggered. Set the full screen hold time here.

Motion Holding Time - How long the recording continues after motion stops.

Sensor Holding Time - How long the recording continues after sensor stops.

Disk Shortage Alarm - If the Partition free space is less than the set percent, the system will stop recording or recycling, but will sound an alert according to the settings.

Alarm Record

Every sensor can trigger multiple channels to record. **For example:** if CAM1, CAM4 and CAM5 are selected for Sensor2, then once the sensor is activated, CAM1, CAM4 and CAM5 will begin to record.

Auto Mail

Any of the alarm types can be configured to generate an alert e-mail but it is especially useful when triggered by a motion detection event.

 **NOTE!** Before configuring the Auto Mail function, be sure to set up Motion Detection.

Click the **Auto Mail** icon on the left top side of alarm configuration page to enter the **Auto Mail Setup Interface**.



PICTURE 7-8

Users can set receiving and sending E-mail SMTP server and address. The address of receiver and sender can be the same. However, this is not recommended as it can overflow your e-mail account. Some free e-mail providers also place a daily limit on the number of e-mails sent and received by a single account.

To test the settings, click **Send Mail Test**. If all settings are okay, response **'Message Sent Successfully'** will pop up. If some settings are wrong, a warning message will pop up.

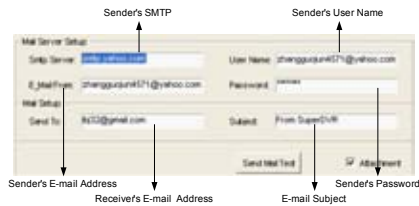

PICTURE 7-9

If **Attachment** is enabled, then a picture of what triggered the alarm will be sent to the selected mailbox.

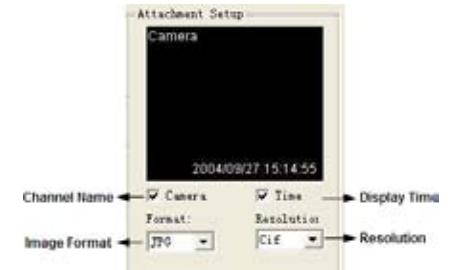

PICTURE 7-10

 **NOTE!** Only one picture will be attached for each alarm event.

7.3 E-MAP CONFIGURATION

E-map is used to show full geographic range covered by the whole monitoring system in the form of map. An E-map features simple operation and direct display of status.

 **NOTE!** The system only supports bmp or jpg image format for E-Map files.

You will need to draw the floor plan of where you want to install the cameras in a program such as Paint or Photoshop and save it in BMP or JPG format before using this feature. Files will be proportionally scaled to 833x678 pixels when in use.

Click on **Emap Edit** and then right-click in the demonstration map currently displayed. Select **Load Picture** in the pop-up. Navigate to where the image is stored on your computer and open the file. The map will be displayed in this interface, allowing you to add the cameras to the map.



PICTURE 7-11

Drag the icon of a camera to the corresponding position on the map, a maximum of 32 cameras can be set simultaneously. Click **Change icon** of camera by right key to change icon or click **Delete** to cancel a camera. After editing, right-click in the map display area and select **Save Map** in the pop-up to save the current map.



PICTURE 7-12

A gray map icon can be drawn to the corresponding position in the map on the right and set it as a sub-map of the current map, or click the gray map icon on the left by right key and select 'Open' to build a new map. You can also click the blue map icon on the left by right key, and select 'Rename' to change the name of the map or select 'Close' to cancel this map. The map tree can only support three levels of maps and submaps.

USING THE E-MAP

To view the E-map during monitoring, click on its icon on the right side of the **Main Display Interface**.

When a channel alarm is triggered, the camera icon will flash a yellow alarm signal. Select 'Auto Show', in case of an accidental alarm, an alarming screen will pop out automatically and you can know about the alarming position immediately. Right-click on the camera to bring up its feed immediately.

Alternately, you can enable Auto Show to bring up the E-map when you're in another viewing mode.

7.4 USER CONFIGURATION

User accounts, privileges and passwords can be added, changed or deleted in this menu. After installing the SuperDVR program, it will automatically create an administrator account with the user name SYSTEM with no password. Users can use this name to log in the system and **Add, Edit or Delete** users' parameters.



PICTURE 7-13

USER RIGHTS

Select a user in the **User Configuration** area, and click Edit to enter the Edit User area

Users can edit user's password and rights here, but not the user name.

The system offers three kinds of rights:

Administrator: this user has the right to change all the settings and playback. This user also has the right to assign users power user rights and normal user rights.

Power User: This type of user is authorized by the administrator. The administrator assigns rights to power users by checking boxes in the Power User list.

Normal User: Normal user's rights are also assigned by the administrator. They have the same list of available rights as Power Users. However, whether they can possess a right is decided by the administrator. Only if the administrator assigns that right, will they have the right. For example, if

Basic Configuration is checked, the Normal User can access these functions.



PICTURE 7-14

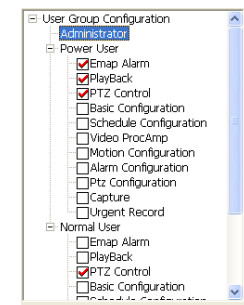

PICTURE 7-15



NOTE! Administrators can change and authorize rights to Power Users and Normal Users, but they cannot change or authorize other Administrators' rights.

ADD USER

Click **Add** in **User Configuration** to access the **Add User** area.

Enter the user name, password, confirm password and select user rights, and then click **OK**.



PICTURE 7-16

Delete User

Select the user name in **User Configuration**, and click **Delete**, and confirm delete.

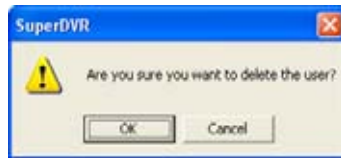

PICTURE 7-17

P.T.Z. CAMERAS

If you are installing a PTZ camera, then the PTZ controls must be set up before operating the camera. You should have your PTZ camera's manual handy when configuring and operating the PTZ camera for the first time. You should have the information regarding the **Baud Rate**, **Protocol** and **Address** ready before you begin.

8.1 P.T.Z CONTROL CONFIGURATION

The PTZ settings are found in the Configuration menu. Click on the wrench icon on the right side of the Display Interface to enter the Configuration menu and then click on the PTZ menu to configure its settings.



PICTURE 8-1

PROTOCOL SETUP

You can select different protocols, serial port number for P.T.Z devices.

The settings you enter here must match the setting on the PTZ camera.

Port - Users can set serial port number.

Protocol - Communication protocol of the P.T.Z device.

SuperDVR supports the following protocols: DSCP, DH-SD, Lilian, Minking, Neon, PelcoD, PelcoP, Star, VIDO, VISCA

Address - Communication address of P.T.Z device (ID number)

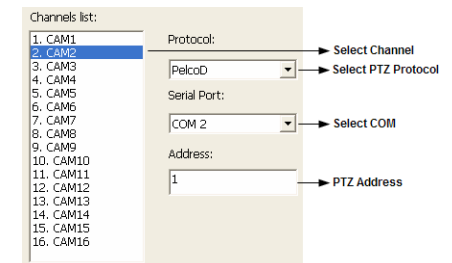

PICTURE 8-2

SERIAL PORTS SETUP

Users should first enable the P.T.Z control function of a camera and then select a port number in P.T.Z Protocol Setup. The values entered for each parameter should match those on the camera itself.

Port - Set the port number.

Baud Rate - Set P.T.Z device Baud Rate to match setting on camera. The default value is 9600.

Data Bits - Default value is 8.

Parity - Odd and even parity bit, default None.

Stop Bits - The Default value is 1.

PICTURE 8-3

8.2 PTZ OPERATION

The PTZ Controls can be accessed directly from the **Main Display Interface** by clicking on the **PTZ Control** icon on the right side of the display. This will replace the buttons and functions on the right side of the display with the PTZ controls.



PICTURE 8-4

You can control P.T.Z. devices by clicking on its display. The selected camera channel will be highlighted in red indicating that it is ready to be controlled.

Focus, Zoom and Iris (light level) are adjusted by the use of the + and - keys to either side.

A PTZ function (direction, zoom, etc.) will continue as long as the user is holding down the left mouse button while the cursor is over the button or until it reaches a physical limit.

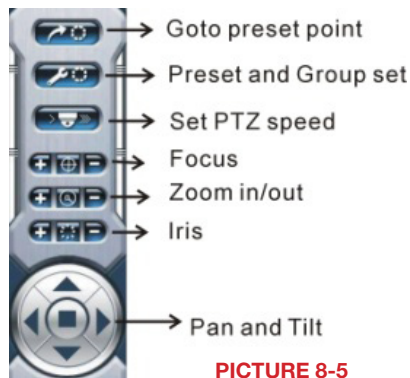

PICTURE 8-5

Clicking on Set PTZ speed allows you to adjust the Pan Speeds, Tilt Speeds, Focus Speeds and Zoom Speeds for all connected PTZ cameras.

Pan Speed - Set horizontal rotating speed.

Tilt Speed - Set vertical rotating speed.

Focus Speed - Set camera focus speed.

Zoom Speed - Set zoom in/ zoom out speed.

PICTURE 8-6

Click  and a pop-up window will appear; users can choose different presets or group sets.

PICTURE 8-7

PRESET AND GROUP SELECT

Click  to set Preset point and change Preset point name. Every Group includes multiple Preset points. If users select preset1, preset2 and preset3 for group1, preset1, preset2 and preset3 will be automatically accessed in sequence after users select group1 for auto scout.

PICTURE 8-8

Preset

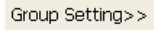
Click , and a pop-up will appear allowing you to configure settings for a Preset.

Dwell- Set the dwell time for a Preset. The camera will wait this long before moving on to the next action.

PICTURE 8-9

REMOTE SURVEILLANCE & PLAYBACK

9.1 REMOTE LIVE SURVEILLANCE

Surveillance system supports Remote Surveillance through LAN, Internet, and Intranet. Simply enable the Webcam function of the system on a computer which is connected to the Internet, and the computer system will become an Internet Webcam server. On any other computer that connects to Internet, enter the public IP server address in an Internet Explorer browser window. Remote users can get high quality real-time image from the server (depending on available bandwidth) and also control the P.T.Z devices.

REMOTE SURVEILLANCE SERVER CONFIGURATION

Users should first enable the Web Camera Services in Basic Configuration and set other settings as shown below:

HTTP Port - Web service & download service port, default value is 80.

Data Port - Data transmission port, default value is 1159.

Command Port - Control command port, default value is 1160.

Picture Quality - Default value is medium.

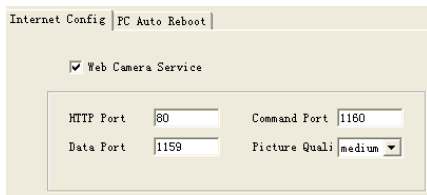

PICTURE 9-1

If your internet connection does not have enough bandwidth available you can use the Picture Quality option to send the video over the internet at a lower quality setting then you are using for recording. That way you will be able to see the images over the internet at lower quality while still recording at the higher quality setting.



NOTE! The minimum speed on the internet connection is 1Mbps download and 1Mbps upload for 4 and 8 channels, and 2Mbps download and upload for 16 channels. You can check the speed of your connection at both ends by going www.SpeedTest.net from both the computer in which the card is installed as well as the remote computer which you will be using.

9.2 CONFIGURING ROUTER FOR REMOTE ACCESS PART 1: FIND OUT THE IP ADDRESS OF THE SYSTEM

STEP 1. To access the router's settings you will need to enter the **Command (CMD)** panel on the computer containing your video capture card.

A. WINDOWS XP – Select **Run** from your Windows **START** menu (lower left of screen) and type “**cmd**” after the prompt.

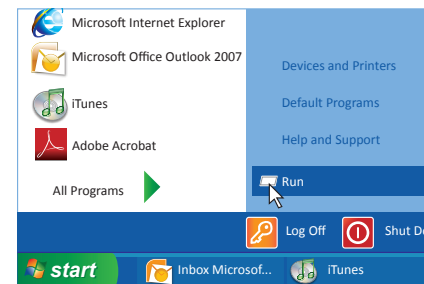

PICTURE 9-2

B. WINDOWS VISTA and WINDOWS 7 – Click on the **START** menu (Windows icon) in the lower left of your screen. Type “**cmd**” into the field that says, “**Search programs and files**” and hit **ENTER** or click on the magnifying glass icon.

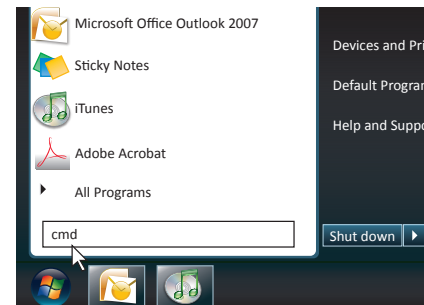

PICTURE 9-3

STEP 2. Type “**ipconfig**” at the prompt (**Red arrow in Picture 9-4**) to access router settings.

STEP 3. Write down the IP4v address (**Blue arrow**) as well as the Gateway and Subnet Mask numbers (**Green arrows**). The IP4v address is the address used by the card.

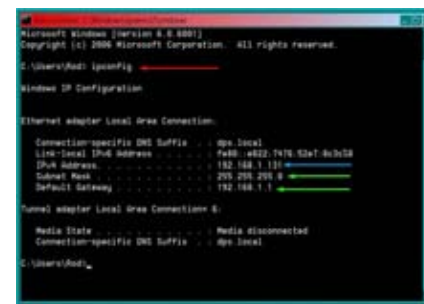

PICTURE 9-4

PART 2: DETERMINE THE NUMBER OF ROUTERS ON THE NETWORK

To find out the number of routers on your network, you will need to download a **FREE** router detection program.

STEP 1. Go to
<http://www.pcwintech.com/shanes-toolbox>

STEP 2. Click on **Detect Multiple Routers** to begin the download.



PICTURE 9-5

STEP 3. Unzip the application to install it.

STEP 4. Click on the **detect_routers** application to run it.

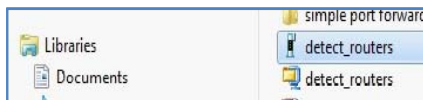

PICTURE 9-6

STEP 5. Click on **CHECK NOW** to detect how many Routers are in the network.

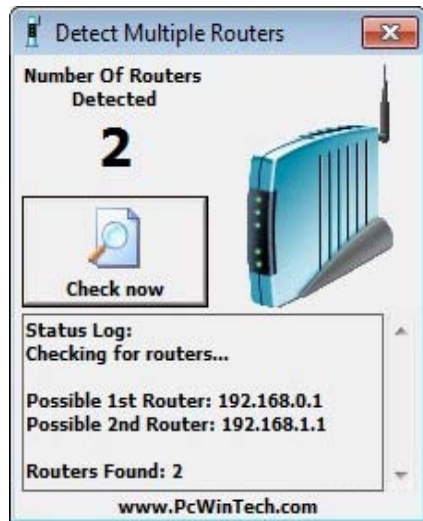

PICTURE 9-7

STEP 6. If there is only one router detected, then you may skip to **Part 3: Simple Port Forwarding**.

If Multiple Routers are Detected

If there are multiple routers, you will see a display similar to **Picture 9-8**.

If so, it may be preferable to connect your DVR and computer to the router that connects directly to the Internet. However, this is not always possible depending upon your particular situation.



PICTURE 9-8

In this case, you will need to proceed with the next section using the IP address for Router 1 to forward its ports. After that, you will need to proceed to **Part 4**.

PART 3: SIMPLE PORT FORWARDING

Download the **FREE** Simple Port Forwarding program from:
<http://www.simpleportforwarding.com/download>

STEP 1. Click on **Download** in any of the mirrors or the Direct Download link to download and install this program.



PICTURE 9-9

STEP 2. Once the program is installed, go to the Windows **Start Menu** (Windows icon in the lower left of your monitor) and look for **Simple Port Forwarding** in the program list. Click on the program to launch it.

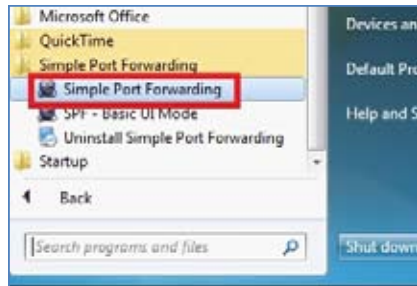

PICTURE 9-10

STEP 3. Once **Simple Port Forwarding** has launched, select your router from the list. The default Router IP and Login information will automatically come up. If you have previously changed the login information, then you will have to enter it manually

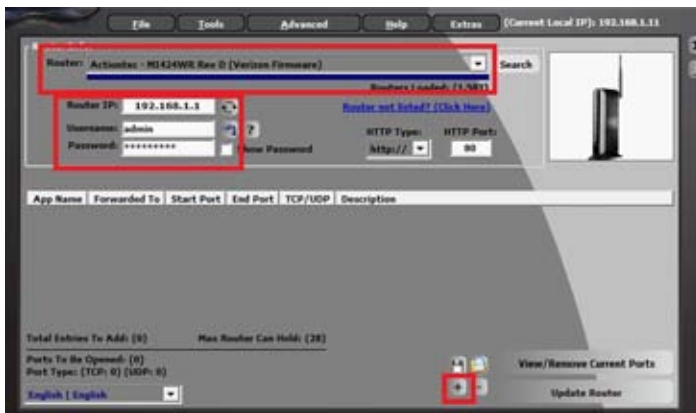

PICTURE 9-11

STEP 4. Click on "+" at the bottom to open the window allowing you to set your ports.

STEP 5. Click on **ADD CUSTOM**.

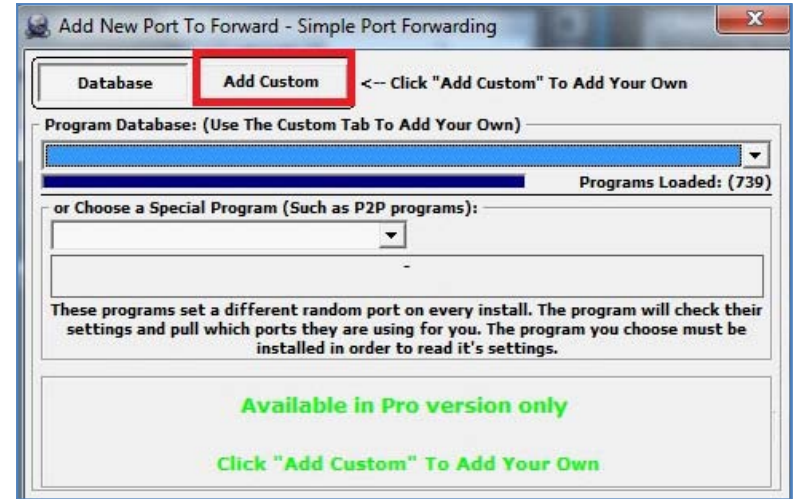

PICTURE 9-12

STEP 6. Input the required information:

Name: (You can name your DVR if you wish)

Type: TCP

Start Port: 80

End Port: 80

IP Address: IP of DVR obtained in

Part 1.

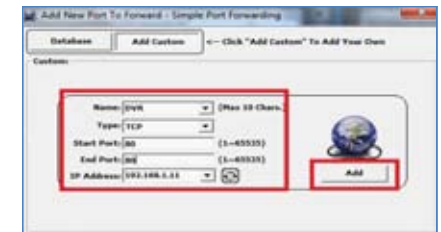

PICTURE 9-13

Click on **ADD**

Repeat for port **1159** and **1160**.

STEP 7. You will now be returned to the main window of the program. The ports you added will now show on the list. Click on **Update Router** at the bottom.

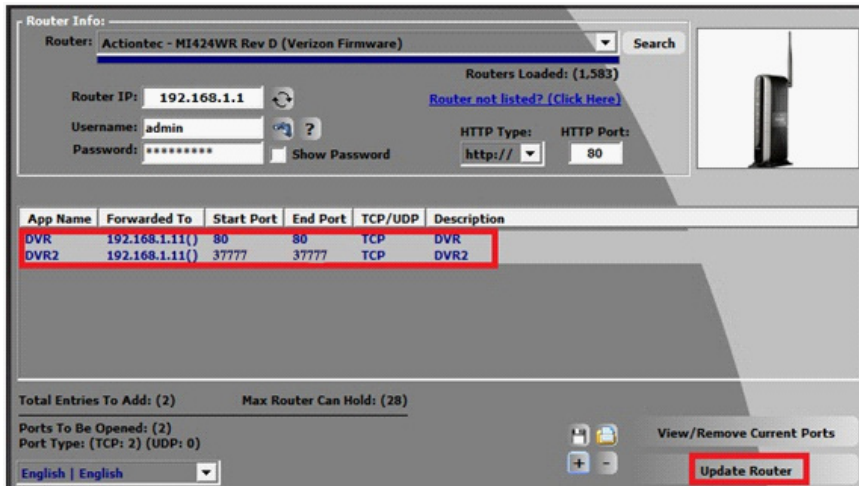

PICTURE 9-14

STEP 8. You will see the "Updating is in progress" message. Please wait until you see it say **DONE** at the bottom.

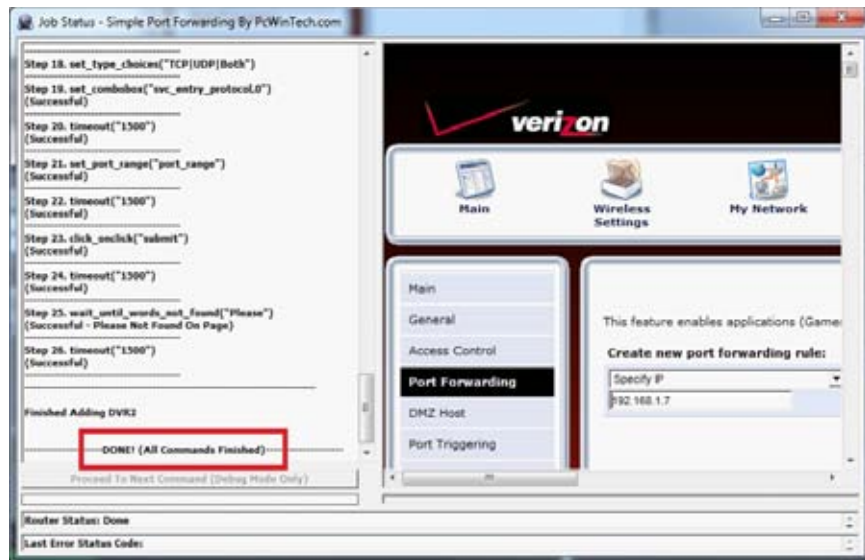

PICTURE 9-15

If for some reason, a port or ports that you forwarded are not listed in the Router and if you see a message in the Scripts list on the left side of the window stating that the port already exists (**Red box in Picture 9-16**), then you will need to change the Port 80 to 85 in the DVR and start over again.

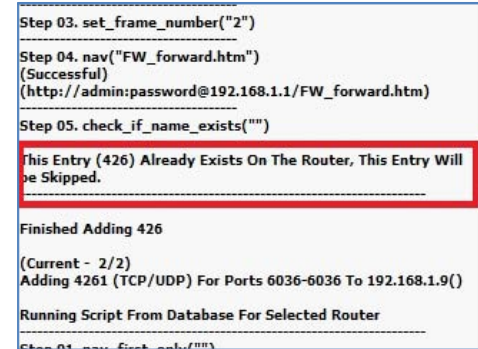

PICTURE 9-16

STEP 9. Once you receive the **DONE** message that the ports have been successfully forwarded, test if the ports are working by clicking on item number 7 in the **Check List** - Test that the ports now work.

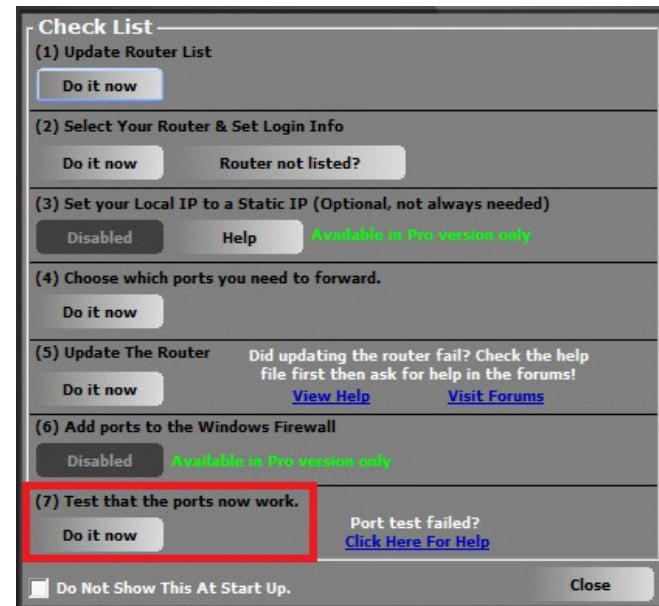

PICTURE 9-17

STEP 10. Click on **Begin**.

If you receive a message stating that the port is online and can be reached, then you have set it up correctly.

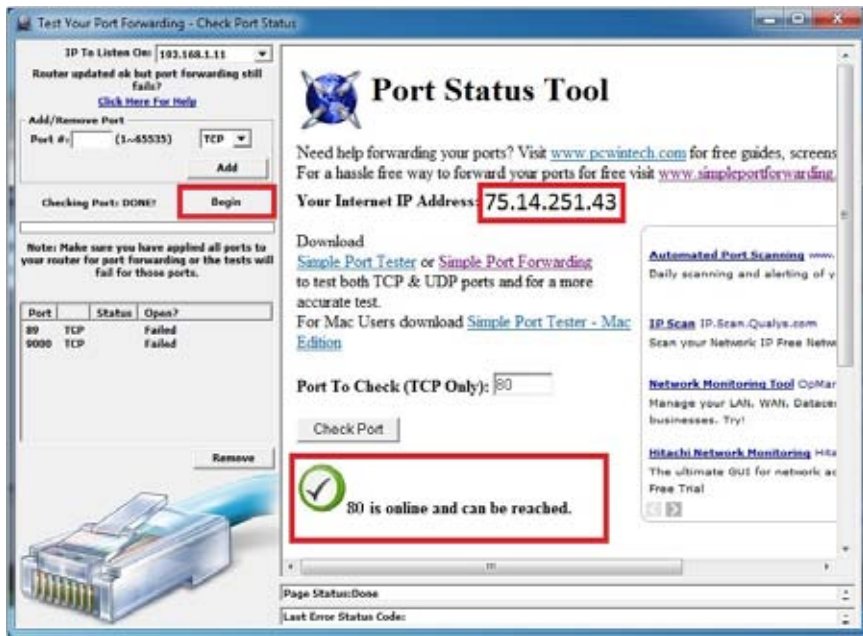

PICTURE 9-18

To connect to your DVR from the Internet, you will need to put the Internet IP address shown after “**Your Internet Address:**” message into your Internet Explorer browser or access program window.



NOTE! The default value is 80. If port 80 is already occupied by another device on the network, then another port will need to be selected. Choose another number in the same range; 81-89. In this case, you will have to add the port to the IP address when entering it into the Internet Explorer window. For example, if the port is now 82, then you will need to enter `http://192.168.0.25:82`



IMPORTANT! Do not use 255 or higher to complete your IP address as these addresses are reserved for other devices and components.

PART 4: SETTING UP DMZ IN ROUTER 2



NOTE! You will only need to proceed with this section if you detected a second router in **Section 2**.

- STEP 1.** Login into Router 1 by putting the IP of Router 1 into the Internet Explorer browser, as in the example shown in **Picture 9-19** where the IP address of Router 1 is 192.168.0.1
- STEP 2.** Find the status page on the router settings that shows the WAN/Internet IP address and write it down this WAN IP address.
- STEP 3.** Log into the Router 2 by putting the IP of Router 2 into the Internet Explorer browser, as in example shown in **Picture 9-19** where the IP address of Router 2 is 192.168.1.1
- STEP 4.** Find the **DMZ** page in the router settings.
- STEP 5.** Enter the WAN IP for Router 1 into the **DMZ** page and enable DMZ.

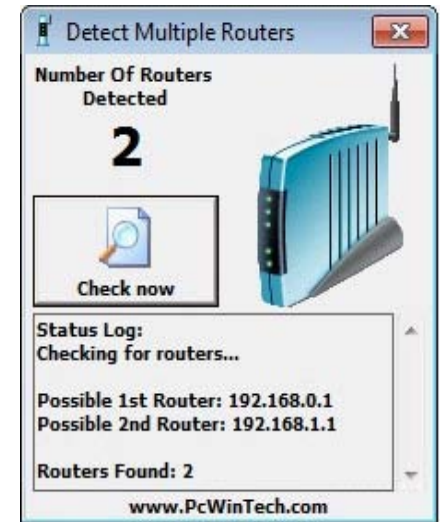

PICTURE 9-19



NOTE! If you do not have a **DMZ** setting in the router, check to see if there is a **Bridge** setting. If so, then use the **Bridge** setting instead of DMZ.

STEP 6. Save your changes.

You have forwarded the ports on the router to which the DVR is connected, to the IP address of the DVR, and set the primary router to pass the connection to this router.

9.3 DDNS (DYNAMIC DOMAIN NAME SERVICE)

You can access the system over the Internet using a static or dynamic IP address. However, your service provider can change this dynamic address from time to time. When it changes, you will have to return to www.MyIPAddress.com to get the new public IP address.

There are two solutions to this problem. The first would be to obtain a static IP address from your ISP – which can be expensive. A second – *and free* – option is to use a dynamic domain name service (DDNS) to get a domain name that can be linked to your dynamic IP address. In addition to automatically keeping up with the changes in the address, you will now be able to enter a domain name rather than a string of digits when accessing the DVR in Internet Explorer.

We recommend using www.MyQ-See.com or www.DynDNS.com as the DVR has been already configured to accept account information from these two services.



NOTE! Before setting up DDNS, you must have previously set up Port Forwarding as described in the previous section.

SETTING UP DDNS

The following instructions are for setting up DDNS with MyQ-See, instructions for DynDNS are available on their website.

STEP 1. Using a computer that is connected to the same router as the DVR, use Internet Explorer to go to www.MyQ-See.com



PICTURE 9-20

STEP 2. Fill out the required information to register and click the **Submit** button at the bottom of the screen.

STEP 3. The next page will ask you to create a domain name. Domain names must begin with a letter (a-z) or a number (0-9) and cannot contain a hyphen. Once you've decided upon a name, click on the **"Request Domain"** button. If it is available you will see a confirmation screen along with the IP address associated with it. Confirm that this matches the number obtained in **Network Settings**. Your domain name will look like this: <http://example.myq-see.com>



PICTURE 9-21

STEP 4. Once you have obtained your domain name, you will need to configure the DVR for access using it.

STEP 5. Once you have completed steps 1-4, click on the link on the MyQ-See website to download the **MyQ-See** software program onto your computer and install it so that it can monitor the IP address assigned to your account. The computer must always be on in order to update the link to the public IP address when it changes.

9.4 ACCESSING THE DVR USING INTERNET EXPLORER

Once you have configured the network settings on the DVR to match those on your router and forwarded the ports needed by the DVR to enable remote access over the Internet, you will be ready to remotely view your cameras using a webcam program based on an ActiveX control. For this to work, you will have to enable the ActiveX control options that are built into Internet Explorer. It is strongly suggested that you be running the latest version of Internet Explorer (currently IE8). The instructions below will describe the process using that version of the browser. Instructions for users with IE6 or 7 are available in the Resources library of our Technical Support page.

USER ACCOUNT CONTROL FOR WINDOWS VISTA AND WINDOWS 7

Some users of computers using Windows Vista or Windows 7 operating systems may receive an error message informing of a codec that is missing or not installed. This conflict can be resolved by turning off User Account Control (UAC).

Windows Vista

STEP 1. Open the Control Panel (accessible by clicking on the Windows icon in the lower left of your screen).

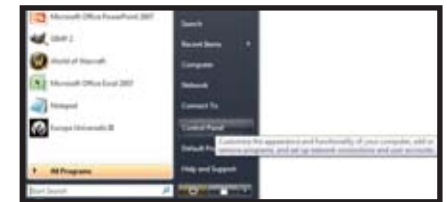

PICTURE 9-23

STEP 2. Select **User Accounts and Family Safety**.

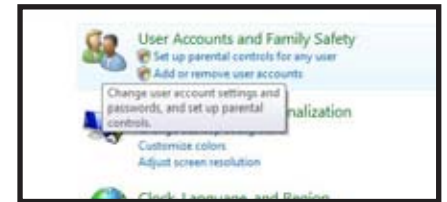

PICTURE 9-24

STEP 3. Select **"Add or Remove User Account."**

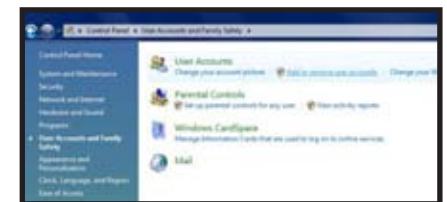

PICTURE 9-25

STEP 4. Select the desired user account.



PICTURE 9-26

STEP 5. Select Turn User Account Control on or off

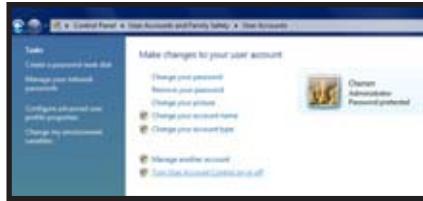

PICTURE 9-27

STEP 6. Uncheck the box next to "Use User Account Control (UAC) to help protect your computer."



PICTURE 9-28

STEP 7. You will then be asked to restart your computer for the change to take effect.



Windows 7

STEP 1. Open up the Start Menu (accessible by clicking on the Windows icon in the lower left of your screen.

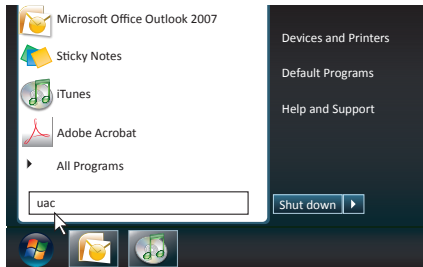

PICTURE 9-29

STEP 2. Type "uac" into the search bar and hit ENTER. The User Account Control will open or you will be offered a link to click to open it.

STEP 3. Move slider to lowest setting and press OK.

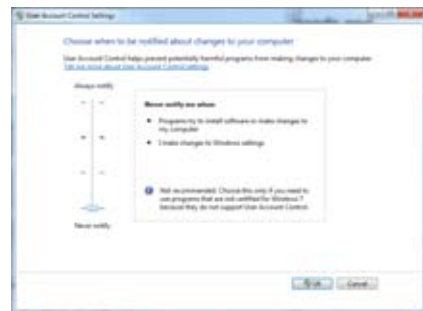

PICTURE 9-31

Setting Up ActiveX Control

STEP 1. Open Internet Explorer

STEP 2. Click on Tools

STEP 3. Select Internet Options in the pull-down menu

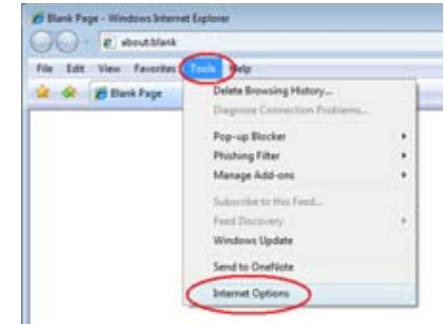

PICTURE 9-32

STEP 4. Click on the Security Tab

STEP 5. Select Trusted Sites

STEP 6. Click on the Sites button



PICTURE 9-33

STEP 7. Uncheck the "Require server verification (https:) for all sites in this zone"

STEP 8. Type the DVR's IP address (obtained during Network Setup) or DDNS domain name into the "Add this website to the zone:"

STEP 9. Click the Add button

STEP 10. Close the window.

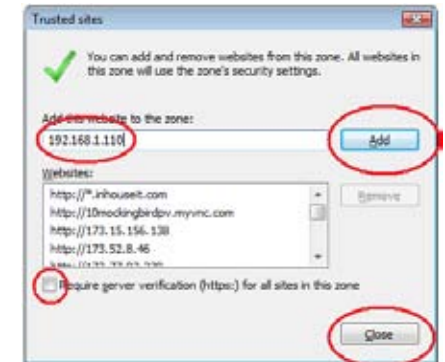

PICTURE 9-34

STEP 11. Click the Custom level... button.



PICTURE 9-35

STEP 12. Pull down the "Reset to:" menu button and select Low

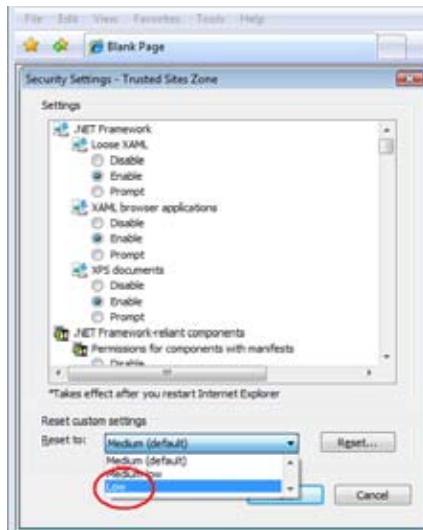

PICTURE 9-36

STEP 13. Click the Reset button

STEP 14. Click "Yes" when asked, "Are you sure you want to change the setting for this zone?"

STEP 15. Click OK

STEP 16. Click Apply

STEP 17. Click OK

STEP 18. Close Internet Explorer

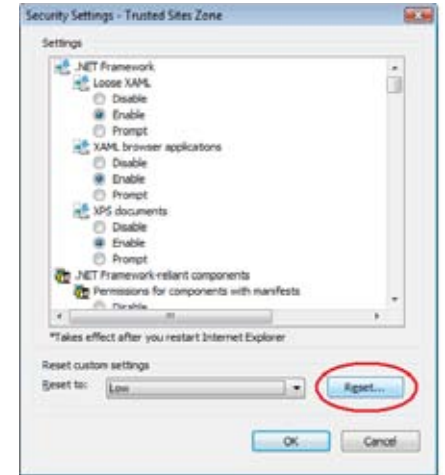

PICTURE 9-37

You are now ready to access the DVR using Internet Explorer.

Open a browser window in Internet Explorer and enter the IP address or DDNS name (obtained in **Section 9.3 DDNS (Dynamic Domain Name Service)**) into the address bar.

You will see a log in screen similar to that shown in **Picture 9-38** or yellow alert bar at the top of the window asking for permission to open an ActiveX application. Allow it to install **webrec.cab control** to reach the sign-in screen.

Instructions for controlling your system remotely are in the next section.



PICTURE 9-38

ACCESSING THE INTERNET EXPLORER CLIENT

After enabling network server on the unit, and enabling ActiveX, users can view the video from the cameras over the LAN or Internet through Internet Explorer. This unit only supports Internet Explorer browser, no other browsers are supported. It also supports Win2000, WinXP, Vista, and Win7.

Input the IP address of the computer with the card if accessing from LAN, or the public IP address of the router if accessing from the internet, into the Internet Explorer window to reach the window that prompts you to install the ActiveX control.

You will get a message asking you to install the file NetVideo.cab. Install it as normal.



PICTURE 9-39

You will then be asked to log in. Use the same User Name and Password as you would when logging in from the computer itself. The default User Name is **SYSTEM** without a password.



PICTURE 9-40

Once you have entered the User Name and Password, click **OK** to log in.

As you can see, the WebCam main interface is very similar to the SuperDVR main interface.



PICTURE 9-41

Icon	Description
	Controls for PTZ Cameras: ▲ Move Up. ▼ Move Down. ◀ Move Left rotate left. ▶ Move Right. ■ Stop Rotating.
	PTZ 'Focus' buttons. + Far Focus - Near Focus
	PTZ 'Zoom' buttons. + Zoom In - Zoom Out
	PTZ 'Iris' button. + Increase light. - Decrease light
	Go to a Preset Point
	Set a Preset Point
	Speed dome. ■ Adjust PTZ speed.
	Single channel with full screen display
	Four channel mode - four cameras displayed
	Contrast adjustment
	Brightness adjustment
	Hue adjustment
	Saturation adjustment
	Log in/ Log out
	Record playback
	System Configuration
	LAN or Master stream is for users on the same network as your system. It has higher frame rate and needs higher network bandwidth Internet, or sub stream, has a lower frame rate and requires lower network bandwidth. Users can select the stream according to their bandwidth.

Right-clicking the mouse in the main interface will open a sub menu.

Open Stream - Click this item, selected channel will open

Close Stream - Click this item, selected channel will close

Close All - Click this item, all channels will close

Full Screen - Select this item, the picture will display full screen. Double click or click right mouse to return to the previous interface.

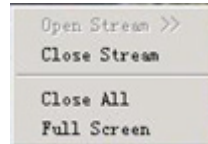





PICTURE 9-42

9.5 REMOTE PLAYBACK RECORD PLAYBACK AND CONTROL

Click  button on the Webcam main interface, and the remote playback interface will appear:



PICTURE 9-43

	Play/ Pause
	Stop
	Adjust the speed of playing back. Users can adjust play speed as needed.
	Playing back backup. Users can click Backup to enter into the Remote Backup interface:

REMOTE BACKUP

STEP 1. Select the date, channel, then click Search button. It will list all files recorded for the day.

STEP 2. Click Browse button, set the saving path.

STEP 3. Select files in the search area. Users can hold shift button on the keyboard and select multi files with mouse simultaneously.

STEP 4. Click Backup button to do remote backup.



PICTURE 9-44

The backup files will be saved in AVI format. Most computer users can play with most third party players directly.

If you do not have a media player installed, we suggest using Windows Media Player Classic which is available as a free download from many web sites and is easily found via an online search.

Right-clicking the mouse in the search area will open a sub menu.

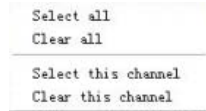

PICTURE 9-45

If you want to view all channels, click **Select all**, then all check boxes before channels will be selected.

Click **Clear all** to clear all selected channels; if users select a certain channel, click **Select this channel**, then just this channel be selected.

Click **Clear this channel** to deselect that channel.

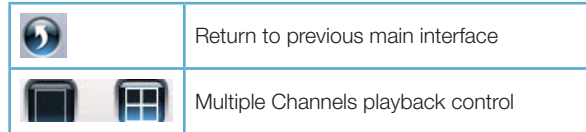

The system default playback modes are single and four channel. If you need to change to other channels, then click the single channel button to bring up the 1-channel configuration window where you can select one channel from all the available channels for playing back.

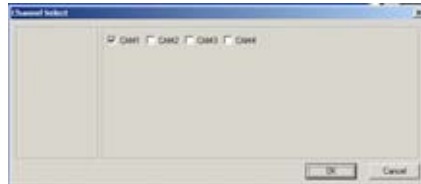

PICTURE 9-46

The four channel configuration window will display when the four channel icon is selected allowing you to select any four channels from all the available channels for play back.



PICTURE 9-47

Data preview shows the recorded data for different channels during corresponding time, the left side shows the available channels. When a certain channel has been selected for playing back, the background color will be highlighted, or its dark gray and a tick sign will appear beside the channel title.

	0	1	2	3	4	5	6	7	8	9	10	11	12	13	14	15	16	17	18	19	20	21	22	23
✓ CAM1																								
CAM2																								
CAM3																								
CAM4																								

PICTURE 9-48

The data preview area at the center gives details of the recorded files. Different colors of the bar show different types of records.

BLUE	Manually Recorded	GREEN	Schedule Recorded
YELLOW	Motion Detection	RED	Sensor Alarm

The ruler on top of the bar shows the hours of the day. Right-click the ruler, it will be magnified 10 times allowing users to see the time marks more clearly.

When searching for a certain section of a record, draw the bar to the desired position. If necessary, right-click the bar to see the magnified time marks for precise search.

You can click the Play button to play the selected record, Then return to live display mode after finishing remote playback, it will display a message 'Connecting...' on the screen. And you may click "Large Picture" or "Quad Picture" button to refresh the screen to get live picture.

9.6 SYSTEM SETUP

Click  and enter the main setup interface.



PICTURE 9-49



NOTE! When multiple clients access the system configuration interface simultaneously, the user who enters into that interface first gets priority and then others will not be able to access it.

BASIC CONFIGURATION

Caption

There are four options: None, ID, Name and ID/Name to select from.

'None' means no title or name.

'ID' means camera numbers, i.e. 1,2,3 and so on.

'Name' means camera names, i.e. Cam1, Cam2 and so on.

'ID/Name' means both camera number and camera name, i.e. 1/Cam1, 2/Cam2 and so on.

Live audio

Your card supports accepts audio input through the RCA ports on the Audio In dongle. You can choose the video channel to associate with these audio signals.



PICTURE 9-50

Server PC Setup

You can enter the user name and password for the computer which houses the video capture card in the appropriate boxes. This way, when the computer system restarts, it will access to the system with the user name and password input in these boxes to begin running the SuperDVR application.

As the Windows system may become unstable after a couple of days of continuous operation. It may cause the SuperDVR system to become unstable. The software supports auto-reboot. Select **PC Autoreboot** and set the interval by day, which will instruct the system to reboot automatically according to your settings.

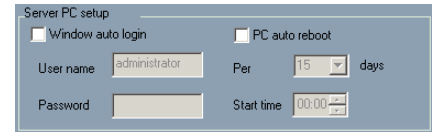

PICTURE 9-51

ALARM SETUP

The Alarm setup configuration is similar to that in the SuperDVR software.

Buzzer - Users can select whether to sound the computer buzzer if the alarms have been triggered also select how long the buzzer sounds.

Full screen alarm - Users can select whether channel will be full screen when alarm triggered. Set the full screen hold time here

Pre-alarm record - Users can select whether to enable alarm pre-recording and also pre-record time

Disk storage alarm - If the Partition's free space is less than the assigned percentage, it will stop recording or recycling, but give alarm tips according to the settings

Motion holding time - The continuous recording time after motion stopped

Sensor holding time - The continuous recording time after sensor stopped

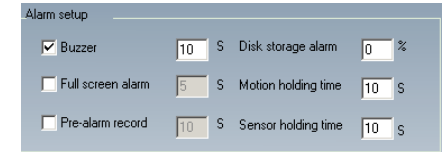

PICTURE 9-52

CAMERA SETUP

 Click the camera icon and the Camera Setup configuration will appear

Title - Channel name. Users can set the channel name from Cam1, Cam2, Cam3 and Cam4.

Camera security - Users are divided into two standards: normal user and super admin. By selecting this option, only administrator can see corresponding channels.



PICTURE 9-53

Time stamp - If selecting the check box, record time will be displayed on the screen when playing back the record.

Net quality - There are five options to choose from: lowest, lower, medium, higher and highest. The higher the picture quality is, the clearer the picture is, but the more bandwidth it takes to transmit the files.

Audio in - If users select the check box, Webcam will record audio along with the video. Otherwise, it will not record audio.



NOTE! The default setting is that Audio input1 matches channel1 and Audio input2 matches channel2

By clicking **Copy To** you can copy the setting of this channel to any other selected channel.

SCHEDULE CONFIGURATION



Click the **Calendar** icon to enter the **Schedule Configuration** page.

There are three kinds of recording modes: manual record, schedule record, motion detection/Sensor alarm record. Users can set schedules from Sunday to Monday separately for all of the three recording modes. Sensor alarm recording mode has the highest priority of the options.

When users need to edit the schedule for a channel, select the camera name in the left Camera group first.



PICTURE 9-54

Click  icon and brush on the weekday schedule to add time; click  icon and click on the weekday schedule to delete time.

By clicking **Copy To** you can copy the setting of this channel to any other selected channel.

ALARM CONFIGURATION

 Click the alarm icon to open the **Alarm Configuration** window

You can set the alarm type: Motion and other. There are two alarm out options to choose from: Buzzer and Auto mail.

Buzzer - Enable buzzer on board for alarm

Auto mail - When alarm is triggered, the system will send an e-mail to users automatically.

By clicking **Copy To** you can copy the setting of this channel to any other selected channel.

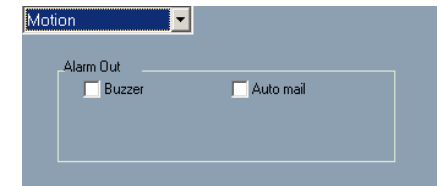

PICTURE 9-55

RECORD CONFIGURATION

 Click the **Record** icon to open the **Record Configuration** interface.

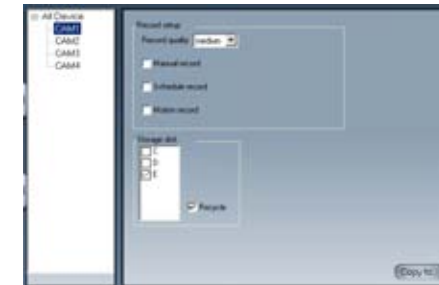

PICTURE 9-56

Record setup

There are three kinds of recording modes: Manual record, Schedule record and Motion record

You can use multiple cameras to record.

Every camera works separately and recorded files are also saved separately.

Record quality - There are five quality options to select from: lowest, lower, medium, higher and highest. The higher the record quality is, the clearer the recorded image is and the more hard space the recording takes up.

Manual record - By selecting this option, the selected camera image will be recorded and saved all the time.

Schedule record - By selecting this option, the selected camera image will be recorded according to the times you setup on the schedule.

Motion record - By selecting this option, users can set selected channels to record when there is motion detected in front of the camera.

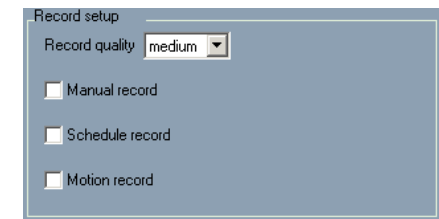

PICTURE 9-57

STORAGE DISK

You can choose where to store recorded files by selecting storage disk. By checking the **Recycle** check box, users can setup the software to continue recording after the hard drive is full by recording over the oldest files on the hard drive.

By clicking **Copy To** you can copy the setting of this channel to any other selected channel.

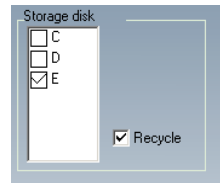

PICTURE 9-58

MOTION CONFIGURATION

Click the running figure icon to access the **Motion Configuration** interface.

Sensitivity - Set motion detection sensitivity here.

Speed - Motion detection speed

Block number - Set grid's number

Select all - Select all the areas of the channel as detection area

Clear all - Clear all the detection areas and then users can select customized detection areas using mouse cursor.



PICTURE 9-59

By clicking **Copy To** you can copy the setting of this channel to any other selected channel.

E-MAIL CONFIGURATION

Click the E-mail icon to access to **E-mail Configuration** interface.

Mail server setup

In this area, users can set receiver and sender's E-mail SMTP server and address. Note: the address of receiver and sender can be the same.

SMTP server - Sender's SMTP, such as smtp.yahoo.com

User name - Sender's User Name

SMTP PORT - Mail server's port, the default value of mail server is 25.

Password - Sender's Password

You can select '**My server requires a secure connections**' or '**My outgoing server (SMTP) requires authentication**' check box according to server mail service policy of mail service provider.

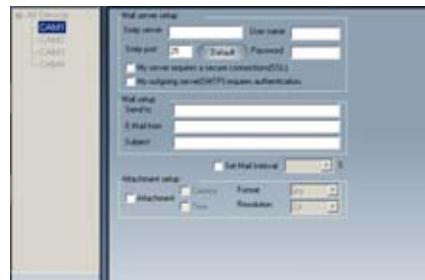

PICTURE 9-60



PICTURE 9-61

Mail setup

Send to - Receiver's E-mail Address

E-Mail from - Sender's E-mail Address

Subject - E-mail Subject

You can select the '**Set Mail Internal**' check box to set e-mail send time, such as 5 seconds, 10 seconds and so on.



PICTURE 9-62

Attachment setup

Select 'Attachment' and the system will attach an image from the camera that triggered the alarm to the designated recipient.

Camera - Channel Name

Time - Display Time

Format - Image Format

Resolution - CIF or QCIF



PICTURE 9-63

9.7 P.T.Z CONFIGURATION

Click the **PTZ** icon to configure the PTZ camera's controls



PICTURE 9-64

PROTOCOL SETUP

Protocol - Communication protocol of P.T.Z device

Port - Set the serial port number

Address - The communication address of P.T.Z device (ID number)

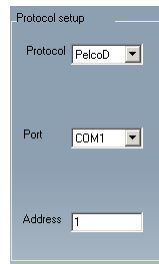

PICTURE 9-65

SERIAL PORT SETUP

You should first enable the P.T.Z control function of selected camera and select a port number in **P.T.Z Protocol Setup** and then set corresponding parameters. You should get the Baud rate, Protocol and Address from your PTZ camera or its manual before proceeding.

Port - Set the port number

Baud rate - Set the P.T.Z device Baud rate, default value is 9600, used value must match Baud rate on PTZ control board

Data bits - The default value is 8, used value must match Baud rate on PTZ control board.

Parity - Odd and even parity bit, default Null, used value must match Baud rate on PTZ control board

Stop bits - Default value is 1, used value must match Baud rate on PTZ control board

Notice: Users should look into the P.T.Z device and get Baud rate, Protocol and Address first, and then set other values accordingly.

By clicking **Copy To** you can copy the setting of this channel to any other selected channel.

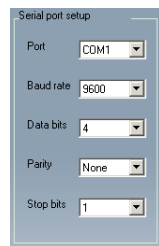

PICTURE 9-66

MOBILE SURVEILLANCE

This video surveillance card supports mobile surveillance on smart phones and other devices running Android, Symbian and Windows Mobile Pro operating systems along with the iPad and iPhone on 3G networks. To access the card from these devices you must have first configured your card for remote access as shown beginning with **Section 9.2 Configuring Router for Remote Access.**

10.1 WINDOWS MOBILE PRO

Windows Mobile Pro 6.1 and 6.5

- STEP 1.** Activate mobile network access on the mobile phone.
- STEP 2.** Run Internet Explorer
- STEP 3.** Input the DVR's IP address or DDNS domain
- STEP 4.** You will be asked to download the software PCam. Click on the software name to open the download dialog pop-up



PICTURE 10-1

- STEP 5.** Click **Yes** to start downloading and installing.



PICTURE 10-2

STEP 6. PCam will open automatically once the install process is complete.



PICTURE 10-3

STEP 7. Input the DVR's address, ID and password respectively in the fields "Server", "User" and "Password". The User Name and Password are the same as used on the DVR. The default is **SYSTEM** with no password. Click "Go" to log onto the DVR. Successful access will bring up the view from a camera.



PICTURE 10-4

STEP 8. Camera 1 is the default channel after login. To change the channel, use the drop-down **Channel** menu.



PICTURE 10-5

10.2 SYMBIAN

This card supports phones running the 3rd or 5th editions of Symbian S60.

STEP 1. Enable network access on the mobile phone.

STEP 2. Launch the web browser

STEP 3. Input the DVR's IP address or DDNS domain name in a new bookmark. Click this bookmark to connect to the DVR.



PICTURE 10-6

STEP 4. A welcome window will open and prompt you to download a software package called SCam. Click on the software name to download.

STEP 5. Click Yes on the security pop-up window to confirm your download

STEP 6. The SCam shortcut icon will appear on the system menu when the download is complete.



PICTURE 10-7

STEP 7. Launch the SCam program. It will display a function interface:

Live View – Open mobile Live View.

Image View – To check pictures snapped in the Live View mode.

System Setting – Login setting and alarm setting

Help – Function indication and help.



PICTURE 10-8

STEP 8. In **System Setting**, select **Login Setting** to bring up the **Login** interface.

STEP 9. Input the DVR's address, User Name and Password then save. The User Name and Password are the same as used on the DVR. The default is **SYSTEM** with no password.

STEP 10. The Access Point of "Winsock" is the default. This access point may differ outside North America or based on your cellular provider. Contact your provider's tech support department if you experience difficulties with this setting.

STEP 11. Open **Live View** to see the camera images.

STEP 12. In **Live View** you can take snapshot images, select other camera channels and control PTZ cameras.



PICTURE 10-9

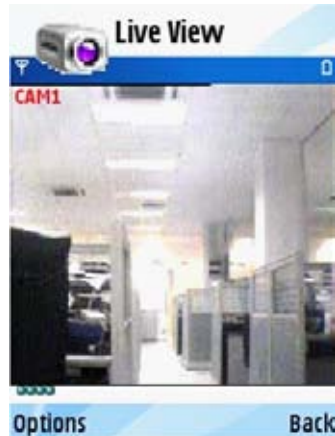

PICTURE 10-10



PICTURE 10-11

10.3 IPHONE AND IPAD

This card supports connection on 3G networks. Non-3G equipped devices will need a Wi-Fi connection.



NOTE! Although the software needed to access your DVR is free, you will need to have or create an iTunes or App Store account to proceed.

INSTALLING THROUGH THE IPHONE OR IPAD

STEP 1. Open the App Store function on your device



PICTURE 10-12

STEP 2. Select the Search function and search for "SuperCam"



PICTURE 10-13

STEP 3. Click on SuperCam to open the introduction. Click on the **FREE** button and it will change to **INSTALL**. Click it again.



PICTURE 10-14



PICTURE 10-15

STEP 4. Input your iTunes or App Store password and then click “OK”. The software will be downloaded and installed automatically.



PICTURE 8-16



PICTURE 10-17

Instructions for operating SuperCam on your Apple mobile device can be found on **page 88**.

INSTALLING THROUGH PC OR MACINTOSH COMPUTER

STEP 1. Access the iTunes store in your computer and login.



PICTURE 10-18

STEP 2. Connect your device to the computer.

STEP 3. Select the Search function and search for “SuperCam.”

STEP 4. Click the “Free Application” button next to SuperCam_Pro. (Red box in **Picture 10-19**)



PICTURE 10-19

STEP 5. Input your Apple ID and password, then click “Acquire.”



PICTURE 10-20

STEP 6. Check “Synchronously Apply Program” and “SuperCam” and then click the **Apply** button. SuperCam will be installed automatically.



PICTURE 10-21

OPERATING INSTRUCTIONS FOR IPHONE/IPAD

STEP 1. Launch SuperCam. This will bring up the **Login** interface.

STEP 2. Input the DVR's IP address or DDNS domain name, User Name and Password. Check the **"Remember Server"** box to save this setting. The User Name and Password are the same as used on the DVR. The default is **SYSTEM** with no password. If you are monitoring multiple devices, previously saved login data for these devices can be accessed using the  button on the right.



PICTURE 10-22

Main Menu

This window contains the function buttons needed to access and control your system.



PICTURE 10-23

Clicking on the **help** icon will list the functions as well as how to use them. They are also defined below:

Button	Function	Button	Function
Playback	Playback recorded files	Image	Image view
Log	Log record	Server List	Device list
Live	Live view	Settings	Software settings
Information	Device information view	Help	Software help center
Logoff	Logoff and return to login interface		

Live View Interface

You can access the different viewing functions of the DVR in a similar manner to the controls on the DVR itself.



PICTURE 10-24



PICTURE 10-25



PICTURE 10-26



PICTURE 10-27











Button	Function	Button	Function
	Switch channels		Switches to PTZ interface
	Snap picture		Record
	Close the video of the current channel		Switch to 4-image view
	Switch to single image view		Zoom In/Focus In/Iris Open
	Move the dome horizontally and vertically. The center square stops the movement.		Zoom Out/Focus Out/Iris Close
		Preset	Select the preset point
Group	Set the cruise line	Speed	Rotate speed of the PTZ
H-Reverse	Inverts PTZ control (up is down)	V-Reverse	Inverts PTZ control (left is right)

Image View Interface

Button	Function
◀	Previous picture
▶	Next picture
◀◀	To first picture
▶▶	To last picture
📄	Copy pictures to album
🗑️	Delete



PICTURE 10-28

Record Playback Interface

Clicking on a recorded file will start the playback. The controls at the bottom of the screen allow the user to move through the video.

Button	Function
▶	Play
⏸	Pause
■	Stop
◀	Reverse
▶	Fast Forward



PICTURE 10-29

Server List Interface

This allows you to add, delete or modify the DVR connection or connections if you are remotely monitoring multiple systems.

Button	Function
★	Add a server
★	Modify a server connection
★	Delete a server

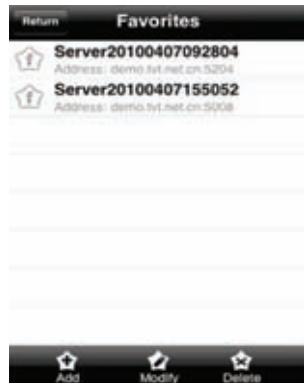

PICTURE 10-30

Configuration Interface

This window allows you to configure the main settings for how files are recorded and saved as well as how alerts are handled.

Record file clip size – This is the maximum size of a single video clip.

Reserved disk space – This is the amount of space reserved for video recordings on the internal memory. If the available disk space is less than that selected, the video will stop.

Display mode – Select between single or four-screen live display

Remember display order – The user can choose whether the phone remembers the display order or not.

Alarm – If turned on, this will trigger an audible alarm when a Video Loss, Sensor or Motion event occurs.

Shake Alarm – If turned on, this will cause the device to vibrate when a Video Loss, Sensor or Motion event occurs.



PICTURE 10-31

Information View Interface

This presents information on the cell phone you are using the SuperCam software version on as well as the software itself.

Device ID: This is the ID of the DVR you are connected to.

Software Version: The current connection device software version

Build Date: The date the software was released

Software Version: The current version of the SuperCam software in use on your phone

Software Build Date: The date this version of SuperCam was released

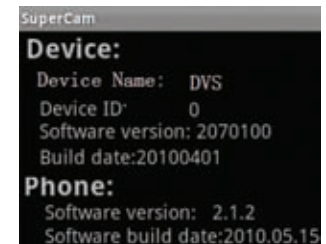

PICTURE 10-32

10.4 ANDROID

SOFTWARE INSTALLATION

STEP 1. Enter the Android Market

STEP 2. Search for “SuperCam”



PICTURE 10-33

STEP 3. Click the **Install** button

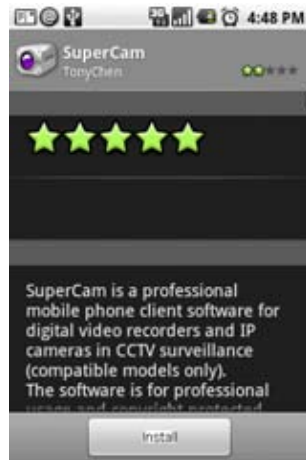

PICTURE 10-34

STEP 4. Click the **OK** button to confirm the download

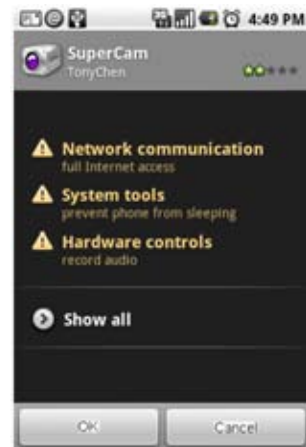

PICTURE 10-35

STEP 5. You can view the download and installation process in Notifications. Once download is complete, the software will install automatically.



PICTURE 10-36

OPERATING SUPERCAM

Login

STEP 1. Launch SuperCam. This will bring up the **Login** interface.

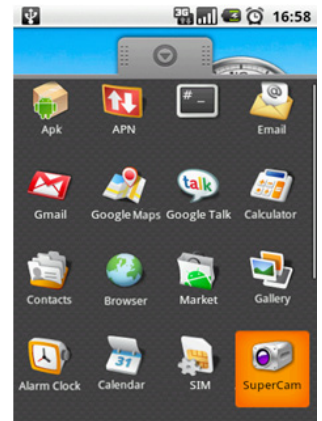

PICTURE 10-37

STEP 2. Input the DVR's IP address or DDNS domain name, User Name and Password. Check the “**Remember Server**” box to save this setting. The User Name and Password are the same as used on the DVR. The default is **SYSTEM** with no password. If you are monitoring multiple devices, previously saved login data for these devices can be accessed using the ▼ button on the right.



PICTURE 10-38

Main Menu

This window contains the function buttons needed to access and control your system.

Clicking on the help icon will list the functions as well as how to use them. They are also defined below:



PICTURE 10-39

Button	Function	Button	Function
Playback	Playback recorded files	Image	Image view
Log	Log record	Server List	Device list
Live	Live view	Settings	Software settings
Information	Device information view	Help	Software help center
Logoff	Logoff and return to login interface		

Live View

In this display you can access the different viewing functions of the DVR in a similar manner to the controls on the DVR itself.

Button	Function	Button	Function
	Switch channels		Switches to PTZ interface
	Snap picture		Record
	Talk		Return
	Full Screen		Zoom In/Focus In/Iris Open
	Move the dome horizontally and vertically. The center square stops the movement.		Zoom Out/Focus Out/Iris Close
		Preset	Select the preset point
Group	Set the cruise line	Speed	Rotate speed of the PTZ

Image View

Button	Function
	Previous picture
	Next picture
	Zoom in
	Zoom out
	Delete
	Return



PICTURE 10-40

Record Playback

Clicking on a recorded file in the **Recorded File** window will start the playback.

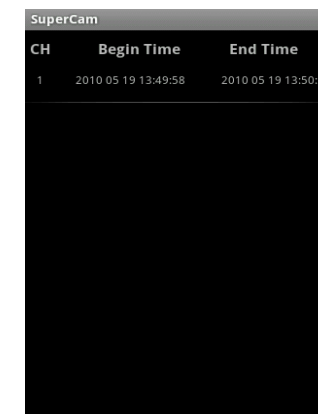

PICTURE 10-41

The controls at the bottom of the screen allow the user to move through the video.

Button	Function
	Play
	Pause
	Stop
	Full screen
	Return



PICTURE 10-42

Server List

This allows you to add, delete or modify the DVR connection or connections if you are remotely monitoring multiple systems.

Button	Function
☆	Add a server
☆	Modify a server connection
☆	Delete a server
☆	Return to Main Menu

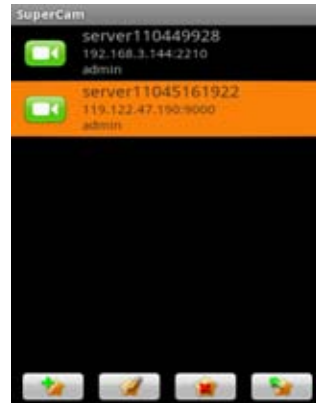

PICTURE 10-43

Information View

This presents information on the cell phone you are using the SuperCam software version on as well as the software itself.

Device ID: This is the ID of the DVR you are connected to.

Software Version: The current connection device software version

Build Date: The date the software was released

Software Version: The current version of the SuperCam software in use on your phone

Software Build Date: The date this version of SuperCam was released



PICTURE 10-44

APPENDIX

FREQUENTLY ASKED QUESTIONS

Installation

Cannot Install the SuperDVR Driver

Possible causes:

- H.264 series capture card has not been installed. Before installing driver, users should install capture card hardware in the PCI slot in the computer case before installing the SuperDVR program.
- H.264 series capture card has not been installed correctly. Please unplug the card and install it again or change to another PCI slot, preferably next to the slot it was originally installed in.
- The card is not compatible with the PC system.

Can't find H.264 Series Devices in Device Manager

Enter the Device Manager and cannot find corresponding H.264 series Devices, the possible cause may be:

- Windows system error. Restart computer.
- Problem with H.264 series card. Replace the card.
- Install SuperDVR to see if it finds card and installs the driver.

Operation

Meanings of the indicator lights

Grey- Normal state

Red - Sensor alarm

Yellow - Motion detection alarm

Blue - Video loss

Light Green - Manual record state

Dark Green - Schedule record state

How do the different record modes work?

Users can set more than one record mode in Record setup (refer to Figure3-5), but actually, there is only one valid record mode for recording.

The priority order of the recording modes is: Sensor Alarm Record > Motion Detection Record > Manual Record > Schedule Record

How to set recycling record mode on the system

Select 'Recycle' in basic configuration, refer to Figure4-1.

Users can select the percent of used disk space to set up "disk shortage alarm." You can input percent manually or choose the selectable options such as, 25%, 50%, and 75% to set up. For example, if selecting 50%, an alarm will warn you when your disk space usage reaches 50%.

TIP It is recommended that you install SuperDVR onto the partition with your Windows system (normally C:), and save recorded files on a different partition.

How to set auto reboot function

When a Microsoft Windows system runs continuously for a couple of days the system may become unstable; therefore, it is suggested you restart the computer every few days. In the basic configuration, input Windows user name and password (It is not SuperDVR user name and password), and select time interval, then the Windows system will automatically restart according to the set time.

If the Windows system shutdown unexpectedly, i.e. power supply is cut off, when computer reboots, SuperDVR system will automatically restart, and keep the settings you have entered.

TIP Users do not need to enable auto reboot function, but it's suggested to input the Windows user name and password in the relative area, therefore when the system shuts down unexpectedly, users don't need to input Windows and SuperDVR user names and passwords.

How to quickly setup the schedule record function

Press 'Shift' or 'Ctrl' key, and draw the cursor in corresponding areas to make schedules for multiple channels.

What are the byte rates for different image qualities from highest to normal?

The frame rate is 30 fps, bit rate for the highest image quality is about 1.2MByte/s, and for the lowest image quality is about 50KByte/s.

The frame rate seems to be lower than what I set

There is frame loss in image switch therefore the real recording frame rate is relatively lower than the theoretic value.

Why can't I select more channels to backup?

Please draw the mouse in the channel selection area, or utilize Shift and Ctrl key for assistance.

How to Use Network Function

How to monitor on the client-side

First enable 'Web cameras service' in basic configuration.

Input the server Internet address in IE browser on the client-side, and the necessary webcam driver will be downloaded automatically, then users need to install the driver. After accessing the webcam main interface, click 'Login' and input user name and password to log in the system.

Why can't I download the client-side software?

The possible causes:

- The client-side computer is not properly connected to Internet or LAN.
- The server-end has not enabled 'Web Camera Service'.
- The default Http port is 80. It may be conflict with other Web servers, for example IIS. If so, please change to another port
- Windows XP SP2 will block the OCX download. You should enable 'Internet Option > Security Settings > Download unsigned ActiveX controls'.

Why can't the server be configured at the client-side?

The possible causes:

- It cannot be configured at the client-side, when the server is being configured at the server-end.
- Only the last configuration is valid if different configurations are deployed simultaneously.

Why can't I see the images?

The possible causes:

- The VGA card is too outdated or does not have enough Video RAM.
- You need to install a newer version of DirectDraw.
- SuperDVR cannot run on a version of Windows before Win2000 or on server versions of Windows
- Data port or command port is conflicting with other network services (please see section 7.2)
- The user is connected to Internet through LAN, and the network administrator has not enabled corresponding data port or command port.
- The client-side has installed firewall software that may stop video transmission.
- H.264 codec has not been installed properly, please download new version of Webcam (newer version of SuperDVR).
- Slow network speed.

What should I do if the Internet speed is quite slow?

The more channels opened, and the slower the video transmission speed, therefore try to use one channel display mode when the network speed is slow.

TIP There may be some surplus channels that have no video input. Switching off the channels will help to improve transmission speed. (Refer to '4.1 Basic Configuration' about switching on/off channels.)

Why can't I start Webcam server or RPB server?

Possible causes:

Other software is using these ports. If so, please change Webcam ports configuration or stop other software.

How much hard drive space do the recorded files take up?

To use the table below, find the picture quality setting you are using and multiply the used space figure by the number of cameras you are recording. Divide the result into the amount of hard drive space available and you will get the number of hours you can record on the available hard drive space.

Example using medium quality with 4 cameras with 200GB available:

$48.12\text{MB} \times 4 \text{ Cam} = 192.48\text{MB/HR}$, $200\text{GB}/192.48 = 1064 \text{ HRs} = 44 \text{ day}$

Frame rate	Resolution	Picture quality	Used Space MB/hour
30fps	640*480	highest	93
30fps	640*480	higher	67.44
30fps	640*480	medium	48.12
30fps	640*480	lowest	10.92

Other Questions

Why doesn't the computer display work, or why can't I access Window system?

The capture card may not be well installed. Unplug the card and try it again.



IMPORTANT! Please unplug the power plug of the computer before re-installing the card to avoid damaging the motherboard chip set.

Why I can't find the recorded files?

You do not have enough hard drive space available for recording.

Why is the screen's display unstable with dithering and water-wave images?

Possible causes:

- Camera does not have enough power
- There is external electromagnetic disturbance, or electrostatic disturbance on camera's BNC connector. Use a shielded RG59 or RG6 cable.
- You may need to update the driver for the video card on the system.
- Problem with the video card. Try reinstalling the video card, or changing the video card.

Why does it delay playing back, and why is it slow to close and open the driver?

Possible causes:

- Problem with the Windows system. Try rebooting the computer.
- There are too many recorded files or too many fragments on the HDD, therefore it takes time to search for the files, you need delete the files that you don't need, or need to run disk defragmenter.
- Capture card problem.
- Computer hardware system is too outdated (processor too slow, not enough memory, or not enough free space on hard drive).

Why can't I play back?

Windows Media Player has been damaged, or decoder has not been installed properly. It is suggested you reinstall the player program or download a codec pack from K-lite www.free-codecs.com/download/K_lite_codec_pack.htm or www.divx.com.

Computer problem, recorded files have been damaged. It is suggested to fix these files using SuperAVIFix program.

Why do I see some gray blocks on time progress bar area when playing back?

Possible causes:

- User has deleted these recorded files.
- SuperDVR has deleted recorded file when recycling hard drive space.
- Recorded files cannot be opened because the recording is on.

Why could I see some old recording sections that weren't available for play back?

Possible causes:

- You previously selected disk partitions different from the current partitions.
- Database of recorded log was damaged.
- You have installed SuperDVR on different directories.

Precautions on changing system time

- The SuperDVR system provides the retrieving mechanism for video files, which must take the system time as a retrieving reference. To change the computer time after installation will create a high risk of wrong time reference.
- Before SuperDVR is used, it must be confirmed whether the current computer time is correct.
- Deactivate computer auto time updating function of system.
- Make sure the motherboard of the computer is in normal state.

If system time must be changed, please do following preparations first

If new time is later than current computer time (for example, change 2006/01/01 0:0:0 (current system time) to 2007/01/01 0:0:0 (target time)), the change can be made directly.

If new time is before the current computer time (for example, change 2007/01/01 0:0:0 (current system time) to 2006/01/01 0:0:0 (target time)), first stop the video recording, backup all video data. Turn off SuperDVR, change computer time, and re-start SuperDVR.

How to use REPAIRDB to repair SuperDVR database

Enter the installation directory of SuperDVR.

C:\ProgramFiles\SuperDVR\SuperDVR, open the REPAIRDB.EXE file. The user ID is 'SYSTEM', and no password is needed to enter. After entering, please select database to repair.

How to set power options of Microsoft VISTA system

After installing VISTA system, you should enter the Start menu to choose 'Control Panel'. Select 'System and Maintenance' link. And select 'Power' option in 'System and Maintenance' window. Finally, Select the 'High Performance Change Plan Setting' option.

QUICK START INSTRUCTIONS

INSTALLATION INSTRUCTIONS

STEP 1. Insert the PCI card (But do not connect the Camera yet).

STEP 2. Launch Windows.

Windows will come up with Hardware wizard. Just click 'Cancel'.

STEP 3. Put the installation CD in the drive and open up SuperDVR folder and run the 'Setup' file.

Step 4. Follow the steps and in WinXP, it will come up with a message saying the program has not passed Windows logo testing, just select 'Continue anyway'.

STEP 5. Reboot computer once installation has completed.

Once Booted up, On Desktop there will be a 'SuperDVR' icon.

If this program recognizes the PCI card, program will open OK. Please log in to the program.

Once your program is opened, now connect the Cameras.

TROUBLESHOOTING

When opening the SuperDVR program, it says ' Can't find card '.

Reboot one more time. If you still have the same problem, click 'Start - Program - SuperDVR - Install' and then uninstall the program. Reboot the computer. After reboot, go back to 'Start - Program - SuperDVR - Install'. Now click on 'Install' to reinstall driver. Then Reboot.

If for some reason still 'Can't find card ', uninstall driver again. Shut down the computer. Move PCI Card to another slot. Reboot it. And click 'Cancel' when Windows detects it.

Then reinstall driver by going to 'Start - Program - SuperDVR - Install'.

How to setup the web client to monitor from Internet

On Main Computer where DVR Card Installed

STEP 1. Make sure the computer is connected to Internet. DSL or Cable Modem, or T1/T3 line.

STEP 2. Find out your router's public IP address. You can go to www.myipaddress from the computer the card is installed in.

STEP 3. Open up the SuperDVR program and go to basic configuration. Checkmark ENABLE Web Camera Service and Remote Play Back Service.

STEP 4. Make Note of Data Port, Command Port and RPB port.

On the Remote Client Computer

STEP 1. Minimum Requirement for the client computer:

- 2.8 GHZ processor or later
- 512 MB RAM
- Windows 2000 (SP4 minimum), Win XP (SP2 minimum), Vista, Windows 7
- MOST AGP and PCI-E cards with 128MB of Video RAM and full Direct Draw support are supported.
- DirectX 9.0 minimum
- 500 GB free space on HDD

STEP 2. Open up Internet Explorer.

If you are running XP with SP2 on Internet explorer, click 'Tools - Internet Option - Security - Custom Level', and enable 'Download unsigned ActiveX controls'.

STEP 3. In the IE textbox of the Internet explorer, input the router's Public IP.

STEP 4. Select 'Live Surveillance' and click 'OK' on displayed page.

This will download the Webcam program. And then you can download Remote Playback as well.

STEP 5. On Desktop now you should see 'Webcam' and 'Remote Playback' icon.

STEP 6. Open up Webcam, click 'Key' symbol icon.

Username: system (Password blank unless you setup a password on the main computer).

Server: this the IP address of the Main Computer.

Data port: 1159 and Command port: 1160.

STEP 7. Click 'OK'. Now you should be able to view the live video from main computer.

STEP 8. To play back the Video that has been recorded in Main Computer, Select 'Remote Playback' on displayed page.

STEP 9. Click on 'Config'.

Remote server: the IP address of main computer.

IP port: 1161.

STEP 10. Then click 'OK'.

STEP 11. Click 'Login'. Now you should be able to play back the recorded video from Main Computer.



NOTE! If you are connecting to internet using a router, you need to configure the setup of the router and do the port forwarding. Ports that need to be forwarded: 80, 1159 and 1160. Check your router manual on how to set that up.

FUNCTION TREE



SYSTEM CONFIGURATION TREE

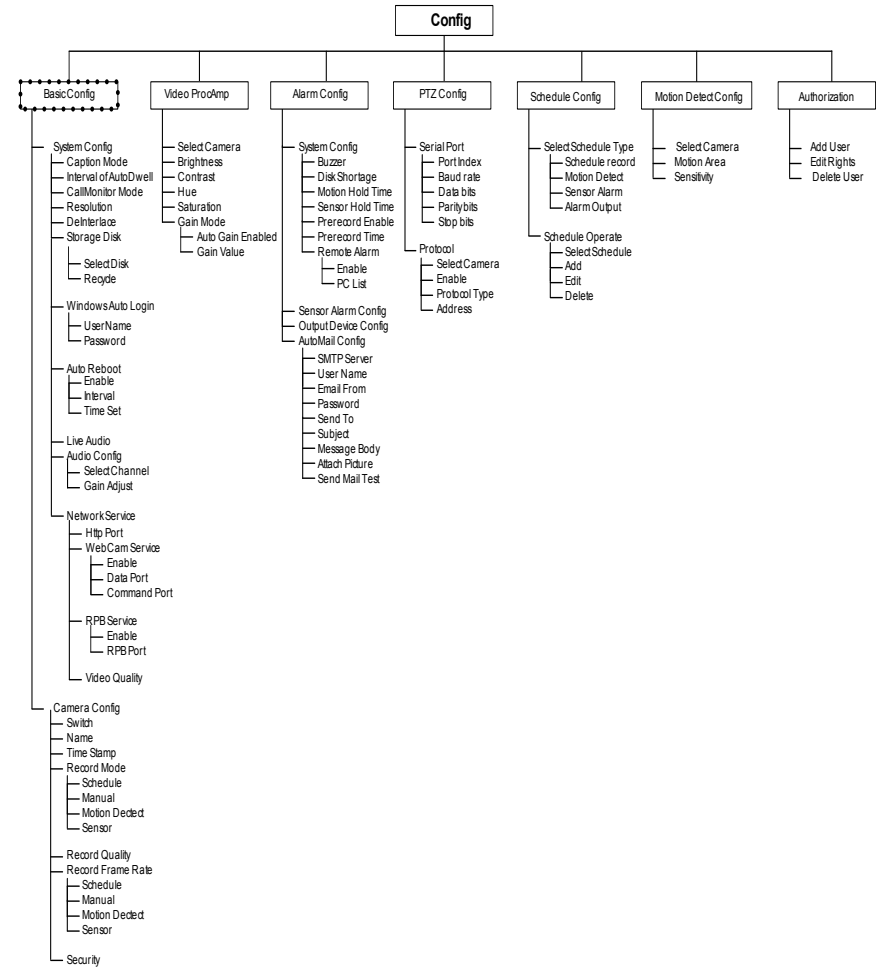

IE CLIENT FUNCTION TREE

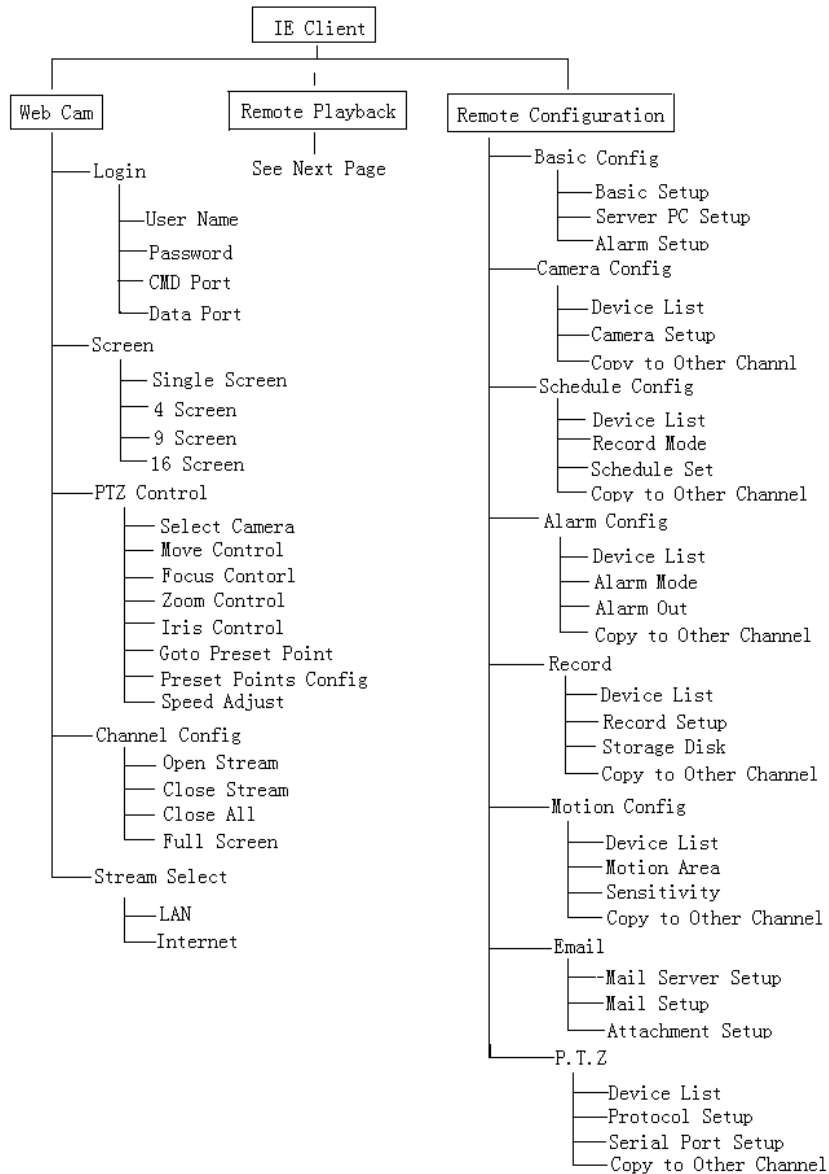

REMOTE PLAYBACK FUNCTION TREE

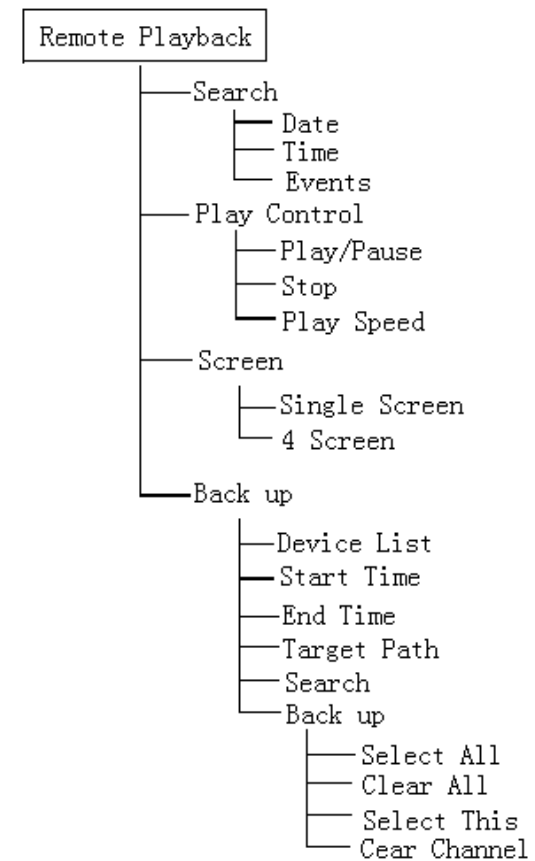

Q-SEE PRODUCT WARRANTY

Q-See is proud to back all of our products with a conditional service warranty covering all hardware for 12 months from the date of purchase. Additionally, our products also come with a free exchange policy that covers all manufacturing defects for one month from the date of purchase. Permanent upgrading service is provided for the software.

Liability Exclusions:

Any product malfunction or abnormalities in operation or damage caused by the following reasons are not within the free service scope of our company:

1. Equipment damage caused by improper operation.
2. Improper equipment operation environment and conditions (e.g., improper power, extreme environmental temperatures, humidity, lightning and sudden surges of electricity).
3. Damage caused by acts of nature (e.g., earthquake, fire, etc).
4. Equipment damage caused by the maintenance of personnel not authorized by Q-See.
5. Product sold over 12 months ago.

In order to fulfill the terms of your warranty, you must complete the registration process after purchasing our product. To do this, simply fill out the User's Information Card on our website at www.Q-See.com



QUESTIONS OR COMMENTS? CONTACT US

MAILING ADDRESS

Q-See Products
Digital Peripheral Solutions, Inc.
8015 E. Crystal Drive
Anaheim, CA 92807

FAX

714-998-3509

WEBSITE

www.Q-See.com

PRODUCT SUPPORT, DOWNLOADS, FIRMWARE UPDATES & MANUALS

www.Q-See.com

CUSTOMER SUPPORT

Live Chat at www.Q-See.com (M-F, 9-5 PST)

E-mail: support@dpsi-usa.com

Phone: 877-998-3440 (M-F, 9-5 PST)

simplicity - quality - technology

Q:see[®]

Digital Peripheral Solutions, Inc.
8015 E. Crystal Drive
Anaheim, CA 92807